

BSM Design Description, Annex B: Interface Control Document: BSM to SPIRE Structure v 1.0

Distribution List

SPIRE-Project	Ken J. King	
	Bruce M. Swinyard	
	Doug K.Griffin	
	Matt Griffin	
UK ATC	Colin Cunningham	
	Gillian Wright	
	Ian Pain	
	Tully Peacocke	
	Brian Stobie	
	Tom Paul	
	Ken Wilson	
MSSL	Berend Winter	

Record of Issue

Date	Index	Remarks
19.Jun.01	1.0	First Issue

Table of contents

DISTRIBUTION LIST	1
RECORD OF ISSUE.....	1
TABLE OF CONTENTS.....	2
FILE DESCRIPTION	2
1. SCOPE.....	3
2. DOCUMENTS.....	3
2.1. APPLICABLE DOCUMENTS.....	3
2.2. REFERENCE DOCUMENTS.....	3
3. FUNCTIONAL DESCRIPTION AND BLOCK DIAGRAM.....	3
4. INPUTS	5
4.1. RESONANCE.....	5
4.2. SCALE FACTOR.....	5
1.3. ASSUMPTIONS.....	6
1.4. SUSPENDED MASSES.....	6
5. OUTPUTS.....	7
6. INTERFACE DRAWING.....	8
7. MASS PROPERTIES.....	13
7.1. ASSEMBLY INERTIA PROPERTIES : SPIRE-BSM-020-001	15
7.2. ASSEMBLY: BSM CHOP AXIS : SPIRE-BSM-020-004	16
7.3. ASSEMBLY: GMBAL FRAME : SPIRE-BSM-020-003	17
8. MECHANICAL ENVIRONMENT.....	18
9. THERMAL INTERFACE.....	18
9.1. FINISH.....	18
9.2. SURFACE AREA.....	18
9.3. CONTACT FORCE	18
10. HARNESS ROUTING.....	19

File Description

Created with: MS Word 97 SR-1
File: BSM_DESIGN_DESCRIPTION_V4.0_annex_B_v1_0.doc

1. Scope

This document outlines the ICD between the BSM (ATC) and the SPIRE structure (MSSL).

The contents of this document are intended for incorporation in the MSSL Structure ICD document, AD4

2. Documents

2.1. Applicable documents

	Title	Author	Reference	Date
AD2	BSM ICD drawing	I.Pain	ATC drawing number: SPIRE-BSM-021-002-001	15.Jun.01
AD3	Structure ICD drawing	MSSL	MSSL drawing number: A2/5264/907	
AD4	ICD Structure - Mechanical I/F	B.Winter	SPIRE-MSS-PRJ-000xxx v1.0	Apr.01
AD5	SPIRE Harness Definition	D.K.Griffin	SPIRE-RAL-PRJ-000608 v0.3	30.May.01
AD6	TBD (harness run mechanical details)		TBD	

2.2. Reference documents

	Title	Author	Reference	Date
RD 1	Thermal Configuration Control Document	S.Heys	SPIRE-RAL-PRJ-000560	18.Apr.01

3. Functional Description and Block Diagram

See BSM Design Description, section 5, 6 for the functional description and general block diagram. The specific ICD block diagram is shown below.

The BSM interfaces directly to the SPIRE Optical Bench and the optical beam. Four elements of the BSM are of relevance to this ICD.

- The baseplate provides location and a thermal path.
- The structural interface locates the BSM mechanism in place.
- The mechanism comprises a nested gimbal mount with a jiggle and chop axis. The mirror is integral to the chop axis.

The Photometer Calibrator (PCAL) has a direct interface to the back of the BSM structural interface, and the PCAL wiring is carried via the BSM cryo-harness.

Thermometers are carried on board the BSM structure, and whilst these will be of use in diagnosis of the BSM thermal condition the thermometry wiring harness is not directly available to the BSM warm electronics.

The Baffle interface ownership is TBD¹. Whilst the baffle mounts to the BSM structure, its features with respect to the optical beam have not yet been fully defined.

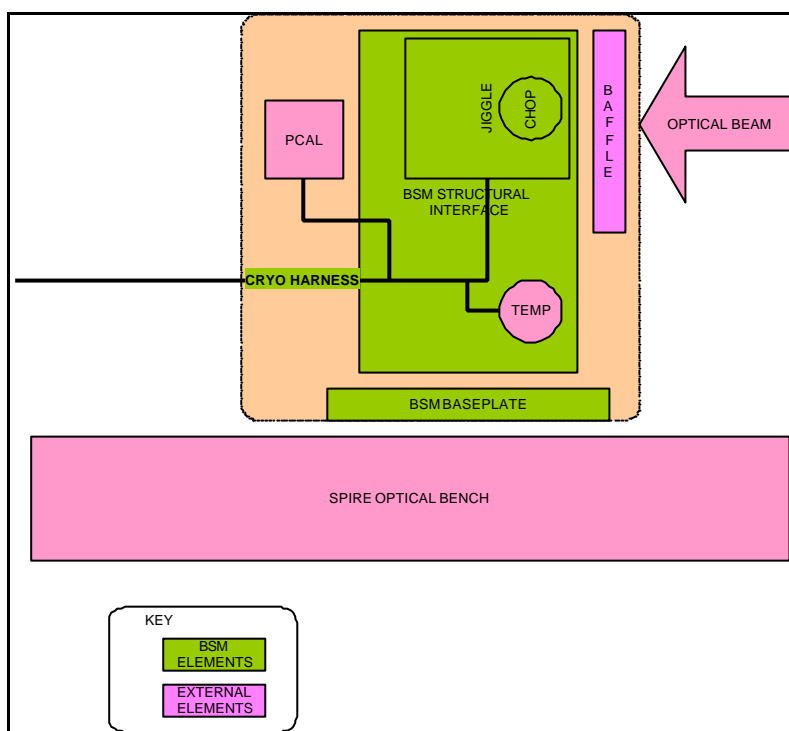

Figure 1 : BSM-STRUCTURE ICD BLOCK DIAGRAM

¹ The baffle may be supplied by ATC or RAL to an agreed specification.

4. Inputs

The BSM receives input vibrations from the structure, at a high level during launch and at a low level during operation (spacecraft micro vibration environment). There is a feedback between the BSM and the structure due to the vibration response of the BSM.

4.1. Resonance

The principal resonant modes of the structure and the two suspended masses are presented below. **A full analysis of the combined system is to be completed.**

The BSM structural interface forms a stiff body. The first twelve structural modes were determined by finite element analysis

FEA prediction for Response of structural interface		Approximate assembly response (see scale factor)
Mode	Frequency (Hz)	Frequency (Hz)
1	688	433
2	864	544
3	1781	1121
4	2715	1710
5	3058	1926
6	3284	2068
7	3345	2106
8	3614	2276
9	3957	2492
10	4097	2579
11	4677	2945
12	5185	3265
	mass of structure	291
	mass of assembly	734
	scaling for resonance	0.630

Table 1: Structural Interface Principal Modes

4.2. Scale factor

Pending a full resonant modes analysis, we may note that since the stiffness of the structural interface design remains unchanged, the assembly natural frequency scales as:

$$f_n = \frac{\sqrt{k/m}}{2}$$

$$\text{hence, } f_{n(\text{assy})} / f_{n(\text{struct})} = \sqrt{m_{\text{struct}} / m_{\text{assy}}}$$

The mass of the structure used for the FEA modes search was calculated at 291gm, and the full assembly mass (excluding contingency, the baseplate and fasteners below the structure base) is predicted at 734 gm . This yields a scaling factor of ~ 0.63, used in Table 1.

4.3. Assumptions

As the structural response remains above 250 Hz it may be assumed to be stiff for subsequent analysis of the SPIRE structure. The actual combined system modes will differ from those presented, due to contributory effects from:

- the effect of bolted joints,
- the contribution of point masses mounted to the structure as distinct from the distributed structural mass
- the resonances of components mounted to it (particularly the baffle, launch lock and motor mounts)

4.4. Suspended Masses

The BSM suspended masses have first natural frequencies approximately as follow:

Axis	Mode	Spring Stiffness (N-m/rad or N/m)	Inertia (kgm ²)	Mass of suspended part (grammes)	1st Resonant frequency (Hz)
Chop	Torsional	0.05875	1.70E-06		29.6
	Radial Orthogonal	1225887.6		16	1393.1
	Radial 45 degrees	875634		16	1177.4
	Axial	1751268		16	1665.1
Jiggle	Torsional	0.4625	4.65E-05		15.9
	Radial Orthogonal	2101521.6		88	777.8
	Radial 45 degrees	1576141.2		88	673.6
	Axial	3152282.4		88	952.6

Table 2 : Suspended Mass Principal Modes

The radial orthogonal rate is where the load is z-x plane or in the plane formed by the optical bench y axis and the BSM gut ray.

The 45 degree radial rate is where the load is applied in line with the plane of a flexure (oriented at 45 degrees to the orthogonal planes).

5. Outputs

The BSM will output a vibration to the Optical Bench during chopping and jiggling. The primary output will be at the chop and jiggle frequencies : 2 Hz and 0.5 Hz respectively, with harmonics **TBD**. Local **TBD** resonances of the BSM (e.g. of the baffle) may modify the harmonics.

Neglecting harmonics and any structural amplification (which should be small anyway, as the structure is stiff) the output forces take the form of a torque reaction in the structure in response to the acceleration of the mirror and jiggle frame in chop and jiggle.

An approximation to this torque reaction may be made by taking the inertia of the moving masses, and an average acceleration over the specified rise time.

BSM reaction loads summary table	Chop (*)	Jiggle (**)	Units
Torque reaction about chop axis (average)	7.12E-06	0	Nm
Torque reaction about jiggle axis (average)	0	9.74E-06	Nm
reaction force at hole at (242.57, 117.2, 526.863)	6.74E-05	1.43E-04	N
reaction force at hole at (351.861, 117.2, 521.426)	-3.37E-05	3.70E-05	N
reaction force at hole at (334.299,117.2, 467.198)	-3.37E-05	3.70E-05	N
* Chop reaction forces in optical bench y-axis			
** Jiggle reaction forces in optical bench z-x plane (normal to BSM jiggle axis)			

Table 3: BSM Reaction Loads

Strictly, these forces are in matched pairs with no net effect. Thus an equivalent 'micro-g' output cannot be attributed to the BSM, i.e., a 'micro-g' input is only resolved at the interface between the optical bench and another supported system.

As a working figure, at a BSM mass of ~0.938 kg, the 'g' loading required to provide this type of force input combining the chop and jiggle loads gives a nominal acceleration at the front hole of 1.69E-04 m/s², i.e. an 'equivalent g loading' of 17.2 micro-g. In reality, the relevant mass is that of the whole structure, which is an order of magnitude more massive than the BSM, this accelerations attributable to the BSM will be below 2 micro-g.

 <p>HERSCHEL SPIRE</p>	<p>BSM Design Description, Annex B: Interface Control Document: BSM to SPIRE Structure V 1.0</p>	<p>Ref: SPIRE-ATC-PRJ-000587 Page : 8 of 19 Date : 19.Jun.01 Author: Ian Pain</p>
---	--	---

6. Interface drawing

- MSSL drawing: A2/5264/907
- ATC drawing: SPIRE-BSM-021-002-001, 4 sheets attached below.
Note: Higher quality prints will be exchanged via DXF format and full size manufacturing prints (A2 or A3)

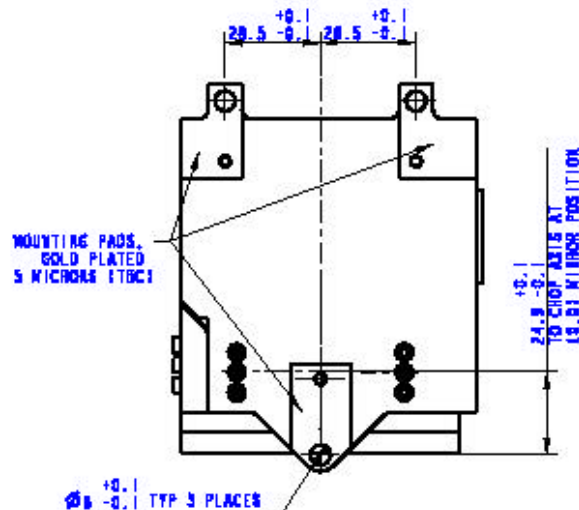
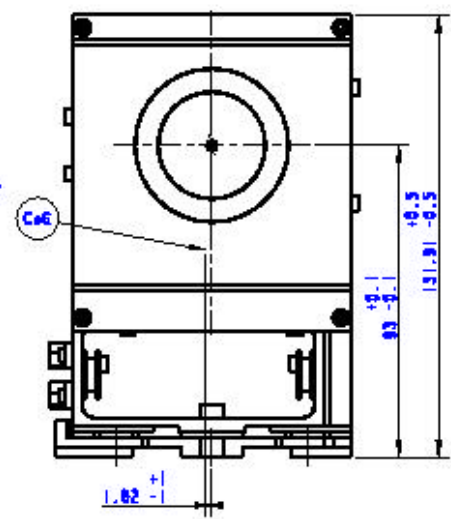
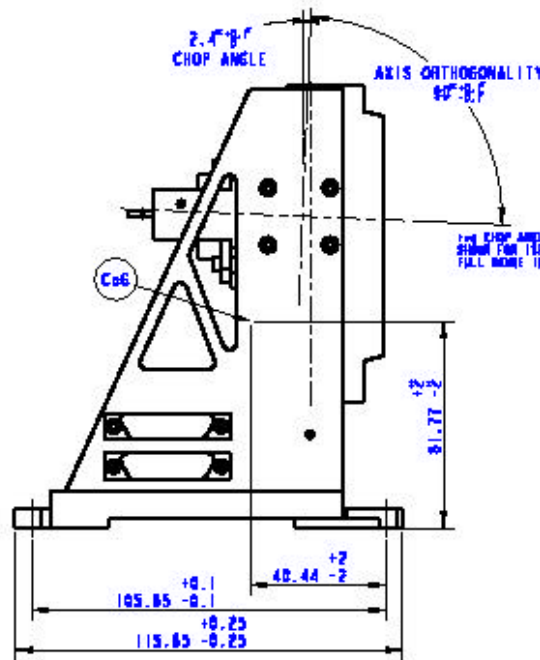
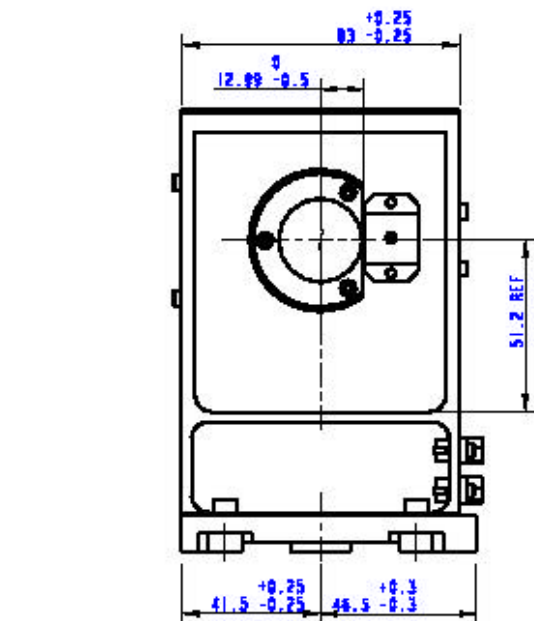

NOTES:

1. THIS DRAWING TO BE READ IN CONJUNCTION WITH INTERFACE CONTROL DOCUMENT SPIRE-ATC-PRJ-000887 ANNEX B (BSM-SPIRE STRUCTURE ICD)
2. CENTRE OF GRAVITY SHOWN BY "CoG"
3. NOMINAL MASS 0.81 kg (0.88 kg including contingency)
4. HARNESS OMITTED FOR CLARITY
5. SURFACE FINISH IS T.B.D.
6. THERMAL STRAP POSITION IS T.B.C

THIRD ANGLE PROJECTION DIMENSIONS IN MM					
Material: N/A		CTO: N/A	Drawn: IP	Date: 15 JUN 01	Rev 1
Finish: SEE NOTE			Mod'd:	Date:	
Tolerances:- Linear : ±0.1 Angular : ±0.5°		Title: BEAM STEERING MIRROR ASSEMBLY ICD			
Size of all sharp edges		Size: a7	Dwg No: SPIRE-BSM-021-002-001	Scale: 1:1	Sheet: 1 of 4

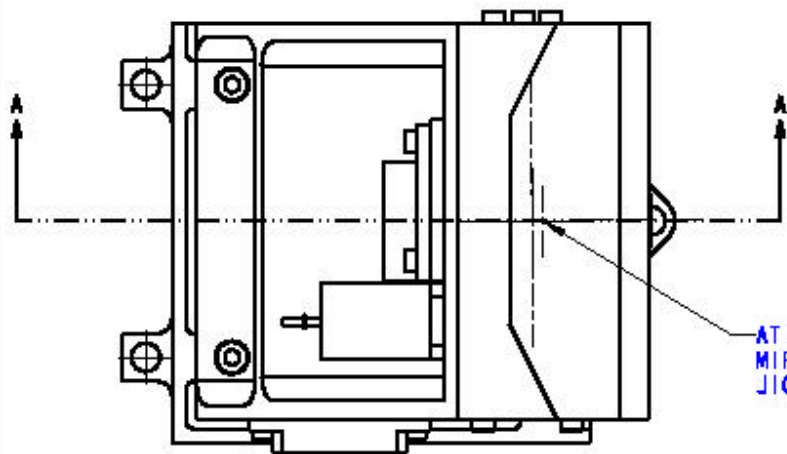

AT (0,0) REST POSITION
MIRROR SURFACE LIES ON
JIGGLE AXIS TO 0.0 +/- 0.1mm

SECTION B-B
THROUGH PCAL AXIS

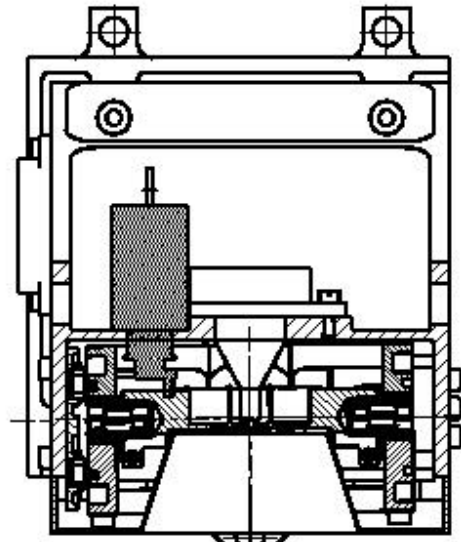

AXIS ORTHOGONALITY
90° ± 0.5°

JIGGLE MOTION
0.6° ± 0.1°

*THE JIGGLE MOTION SHOWN
FOR INFO, FULL MOTION
IS +/- 0.5°

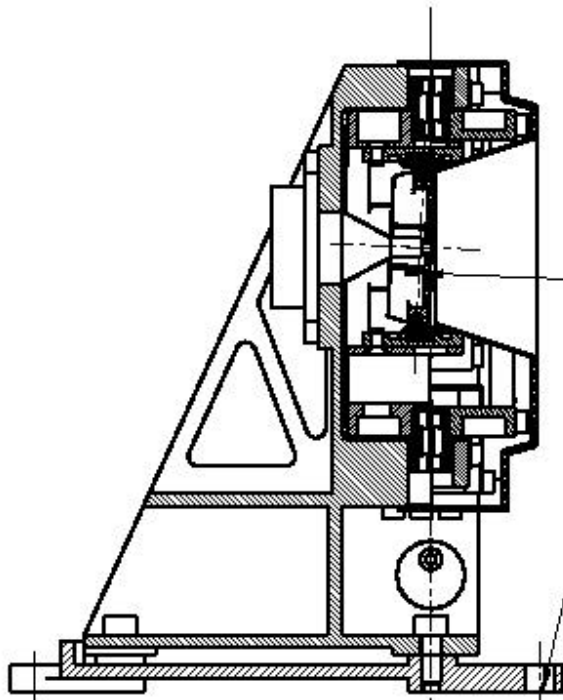

+0.1
2.25 -0.1
MIRROR OFFSET
FROM CHOP AXIS

POSITION OF THIS HOLE FROM OPTICAL
BENCH DATUM ON MSSL DRG A2/5264/907
IS (242.57, 117.2, 526.863) mm

SECTION A-A

+0.1
22.65 -0.1
TO JIGGLE AXIS

THIRD ANGLE PROJECTION
DIMENSIONS IN MM



UK Royal Observatory
Astonomy Technology Centre
Blackford Hill
Edinburgh
EH8 3HJ

Material: N/A
Finish: SEE NOTE

CTD:-
Drawn: IP Date: 15 JUN 01
Mod'd: Date:

Unless otherwise stated

Least mod:

Tolerances:-
Linear : ±0.1
Angular : ±0.5°
Remove all sharp edges

Title: BEAM STEERING MIRROR ASSEMBLY ICD
(SECTIONS SHOWING MIRROR POSITION)

Size A3	Dwg No: SPIRE-BSM-021-002-001	Rev 1+
Scale:	MODEL: SPIRE-BSM-020-001	Sheet 3 OF 4

THIS SHEET SHOWS 3D VIEWS OF THE ASSEMBLY FOR INFORMATION ONLY
 NOTE: HARNESS REMOVED FOR CLARITY.

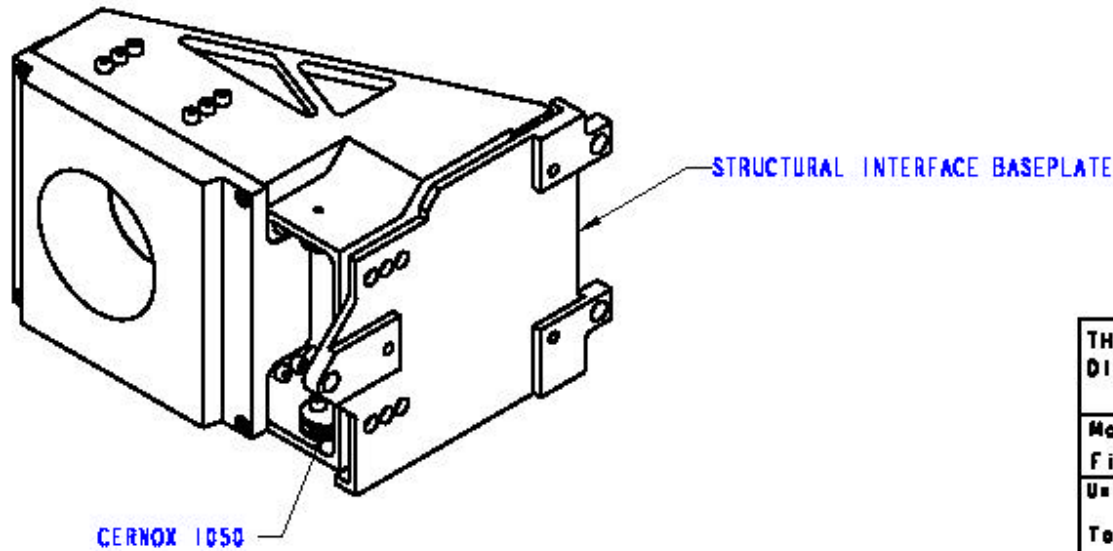
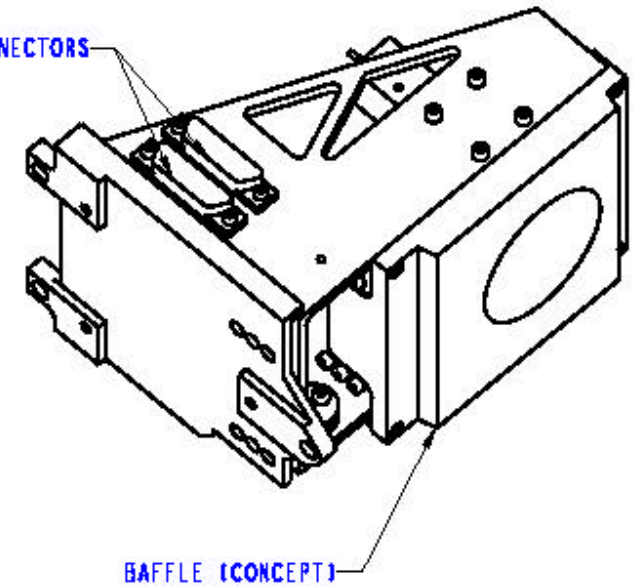
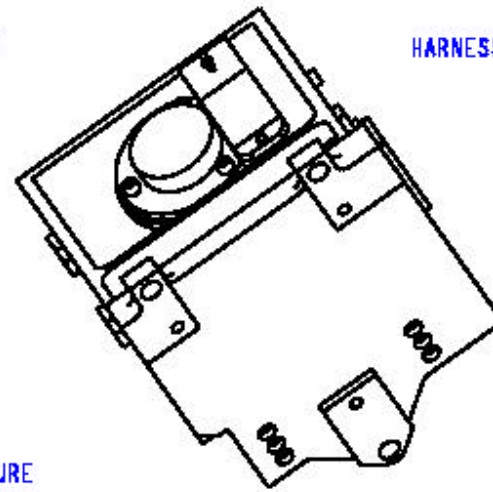
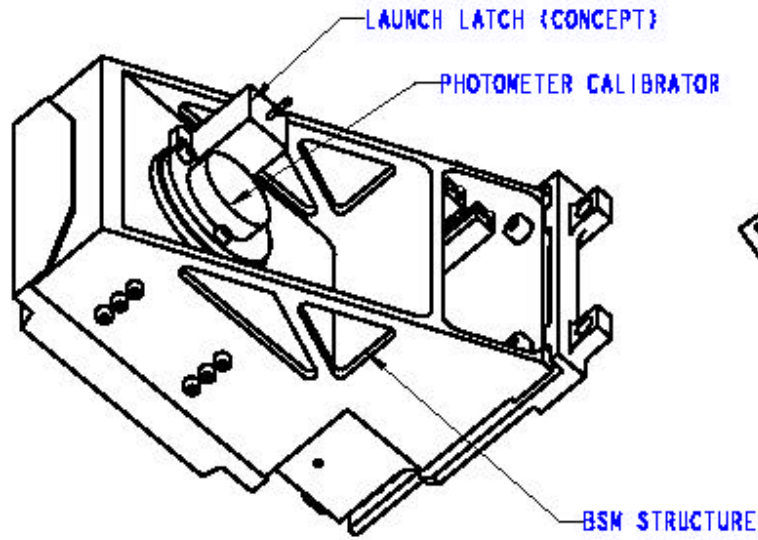

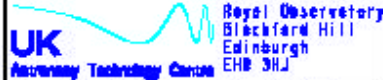
THIRD ANGLE PROJECTION DIMENSIONS IN MM					
Material: N/A		CTD:-		Drawn: IP Date: 15. JUN. 01	
Finish: SEE NOTE				Mod'd: Date:	
Unless otherwise stated		Last mod:			
Tolerances:-		Title: BEAM STEERING MIRROR ASSEMBLY ICD (INFORMATION VIEWS)			
Linear : ±0.1		Size A3		Dwg No: SPIRE-BSM-021-002-001	
Angular : ±0.5°		Scale:		Rev 1+	
Remove all sharp edges		MODEL: SPIRE-BSM-020-001		Sheet 2 OF 4	

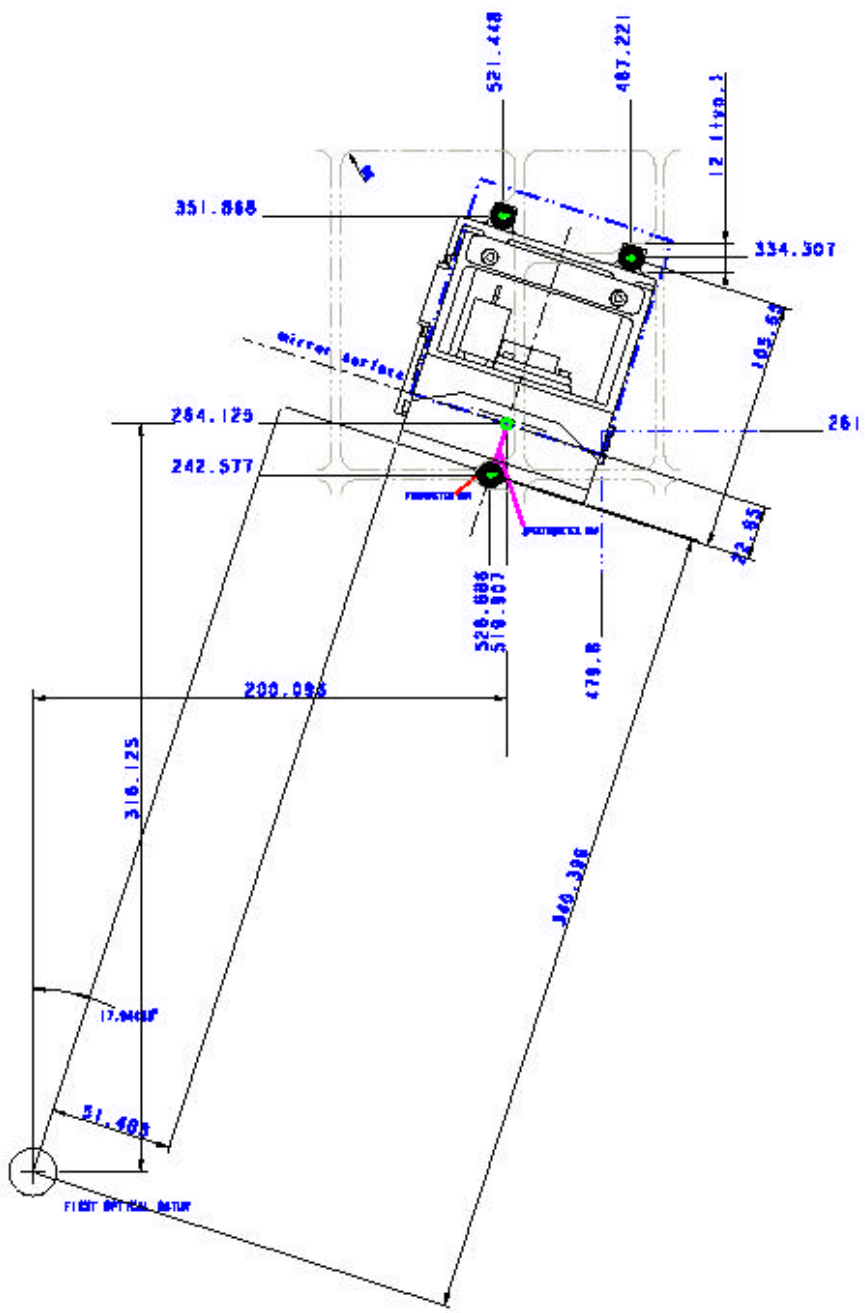

X=52.00 Y=117.28 Z=-720.00
(FROM FIRST OPTICAL DATUM)

NOTE:
 ALL DIMENSIONS ON THIS DRAWING SHEET ARE T.B.C.
 BEM nominally positioned normal to Prismatic Gut Ray
 Obtained from table in NSSL drg no A2/S264/1071
 i.e. 17.9448° off the telescope axis



THIRD ANGLE PROJECTION DIMENSIONS IN MM				Royal Observatory Greenwich Hill (London SE10 8XJ)
Material: UK Finish: SEE NOTE, SHEET 1	CTB: --- Mod'd: ---	Drawn: TP Date: 15.11.11	Checked: --- Date: ---	
Tolerances:- Linear : ±0.1 Angular : ±0.5'	Title: BEAR STEERING RING ASSEMBLY (CD OPTICAL BENCH OVERLAY)	Scale: --- Date: ---	Part No: SP1RE-BEM-021-002-001	Rev: 1
Remove all sharp edges	SCALE: ---	Dwg No: ---	Sheet 4 of 4	

7. Mass Properties

MASS BREAKDOWN OF THE SPIRE BEAM STEERING MIRROR ASSEMBLY			v1.2	dated 16.Jun.01					
MODEL : SPIRE-BSM-020-001									
Part Number	DESCRIPTION	MATERIAL:	DENSITY (kg/mm ³)	COMPONENT MASS (kg)	QUANTITY	ASSY. MASS (kg)	CONTINGENCY (%)	CONTINGENT MASS (kg)	MASS INCL CONTINGENCY (kg)
SPIRE-BSM-020-001-001	BSM STRUCTURAL INTERFACE	AL_TO_BS_1470_6082	2.78E-06	0.2910	1	0.2910	10%	0.0291	0.3201
SPIRE-BSM-020-001-002	BASEPLATE	AL_TO_BS_1470_6082	2.71E-06	0.0838	1	0.0838	10%	0.0084	0.0922
SPIRE-BSM-020-001-003	JIGGLE AXIS FLEX CLAMP (L)	AL_TO_BS_1470_6082	2.71E-06	0.0026	1	0.0026	10%	0.0003	0.0029
SPIRE-BSM-020-001-005	JIGGLE AXIS FLEX CLAMP (U)	AL_TO_BS_1470_6082	2.71E-06	0.0023	1	0.0023	10%	0.0002	0.0026
SPIRE-BSM-020-001-004	PCAL SPACE ENVELOPE	ASSEMBLY	6.00E-06	0.0507	1	0.0507	25%	0.0127	0.0633
SPIRE-BSM-020-001-006	BAFFLE (CONCEPT)	AL_TO_BS_1470_6082	2.72E-06	0.0337	1	0.0337	50%	0.0169	0.0506
SPIRE-BSM-020-001-007	LAUNCH LATCH (ENVELOPE)	ASSEMBLY	7.00E-06	0.0509	1	0.0509	25%	0.0127	0.0636
SPIRE-BSM-020-003	GIMBAL ASSEMBLY	ASSEMBLY	3.23E-06	0.0883	1	0.0883	10%	0.0088	0.0971
SPIRE-BSM-020-005	COIL ASSEMBLY	ASSEMBLY	2.06E-06	0.0133	4	0.0534	10%	0.0053	0.0587
SPIRE-BSM-020-006	SENSOR ASSY JIGGLE	ASSEMBLY	2.45E-07	0.0004	1	0.0004	10%	0.0000	0.0004
SPIRE-BSM-020-008	SHIELDED FLEXURE ASSY	ASSEMBLY	7.73E-06	0.0031	2	0.0063	15%	0.0009	0.0072
SPIRE-BSM-020-009	HARNES ASSY (CONCEPT)	ASSEMBLY	2.71E-06	0.0046	2	0.0092	50%	0.0046	0.0138
DISC-SPRING-ID-3_2	DISC SPRING	STAINLESS-STEEL	7.91E-06	0.0000	4	0.0002	10%	0.0000	0.0002
CERNOX-THERMISTOR	CERNOX-THERMISTOR	COPPER-CANISTER	8.90E-06	0.0048	2	0.0096	10%	0.0010	0.0105
CAP-HD-SCREW-SS-M4X10	CAP-HD-SCREW-SS-M4X10	STAINLESS-STEEL	7.91E-06	0.0020	3	0.0061	10%	0.0006	0.0067
CAP-HD-SCREW-SS-M2X10	CAP-HD-SCREW-SS-M2X10	STAINLESS-STEEL	7.91E-06	0.0004	4	0.0016	10%	0.0002	0.0018
CAP-HD-SCREW-SS-M2-5X7_75	CAP-HD-SCREW-SS-M2-5X7_75	STAINLESS-STEEL	7.91E-06	0.0006	2	0.0011	10%	0.0001	0.0013

MASS BREAKDOWN OF THE SPIRE BEAM STEERING MIRROR ASSEMBLY			v1.2	dated 16.Jun.01					
MODEL : SPIRE-BSM-020-001									
Part Number	DESCRIPTION	MATERIAL:	DENSITY (kg/mm ³)	COMPONENT MASS (kg)	ASSY. MASS (kg)	CONTINGENCY (%)	CONTINGENT MASS (kg)	MASS INCL CONTINGENCY (kg)	
					QUANTITY				
CAP-HD-SCREW-SS-M2-5X7	CAP-HD-SCREW-SS-M2-5X7	STAINLESS-STEEL	7.91E-06	0.0005	15	0.0081	10%	0.0008	0.0089
CAP-HD-SCREW-SS-M2-5X6	CAP-HD-SCREW-SS-M2-5X6	STAINLESS-STEEL	7.91E-06	0.0005	8	0.0040	10%	0.0004	0.0044
CAP-HD-SCREW-SS-M2-5X12	CAP-HD-SCREW-SS-M2-5X12	STAINLESS-STEEL	7.91E-06	0.0007	4	0.0029	10%	0.0003	0.0032
37WAY_CONN	37 WAY MDM CONNECTOR	CONNECTOR	2.10E-06	0.0063	2	0.0125	20%	0.0025	0.0150
UN-MODELLED PARTS (approx. mass only)	ADHESIVE	ADHESIVE	2.00E-06	0.0010	10	0.0100	10%	0.0010	0.0110
	P-CLIPS	BRASS (TBC)	8.45E-06	0.0003	16	0.0055	10%	0.0006	0.0061
	P-CLIP FASTENERS	STAINLESS-STEEL	7.91E-06	0.0004	16	0.0064	10%	0.0006	0.0071
	MDM FASTENERS	STAINLESS-STEEL	7.91E-06	0.0004	4	0.0016	10%	0.0002	0.0018
	LOCKING INSERTS	STAINLESS-STEEL	7.91E-06	0.0003	56	0.0168	20%	0.0034	0.0202
	DOWELS	STAINLESS-STEEL	7.91E-06	0.0001	8	0.0009	15%	0.0001	0.0010
	COATING	Nickel (10um) & Gold (3 um)	1.13E-05	0.0159	1	0.0159	15%	0.0024	0.0183
	PAINT	QMW BLACK (40 um)	3.00E-06	0.0130	1	0.0130	15%	0.0019	0.0149
	LACING	TBD	1.50E-06	0.0020	2	0.0040	15%	0.0006	0.0046
					TOTAL	0.7927	TOTAL CONTINGENCY	0.1166	
					TOTAL INCLUDING CONTINGENCY				0.9093
					NB: excludes cryo-harness x2 and shoulder bolts for mount to optical bench				

Table 4: BSM Mass Breakdown

7.1. Assembly Inertia Properties : SPIRE-BSM-020-001

The analysis below is performed on the BSM assembly model. However, it neglects the un-modelled components discussed in Table 4 above.

VOLUME = 2.3301650e+05 MM³
 SURFACE AREA = 2.1612245e+05 MM²
 AVERAGE DENSITY = 3.0643866e-06 KILOGRAM / MM³
 MASS = 7.1405265e-01 KILOGRAM

CENTER OF GRAVITY with respect to CS0 coordinate frame:

X Y Z -1.8016179e+00 4.0471565e+01 5.8857929e+01 MM

INERTIA with respect to CS0 coordinate frame: (KILOGRAM * MM²)

INERTIA TENSOR:

Ixx Ixy Ixz 5.1366739e+03 9.2292278e+01 3.4535460e+01
 Iyx Iyy Iyz 9.2292278e+01 4.1046018e+03 -1.4494497e+03
 Izx Izy Izz 3.4535460e+01 -1.4494497e+03 2.0149595e+03

INERTIA at CENTER OF GRAVITY with respect to CS0 coordinate frame:
 (KILOGRAM * MM²)

INERTIA TENSOR:

Ixx Ixy Ixz 1.4934320e+03 4.0227633e+01 -4.1182323e+01
 Iyx Iyy Iyz 4.0227633e+01 1.6286230e+03 2.5147549e+02
 Izx Izy Izz -4.1182323e+01 2.5147549e+02 8.4306099e+02

PRINCIPAL MOMENTS OF INERTIA: (KILOGRAM * MM²)

I1 I2 I3 7.6590064e+02 1.4934970e+03 1.7057184e+03

ROTATION MATRIX from CS0 orientation to PRINCIPAL AXES:

	0.06976	0.98932	0.12798
	-0.28216	-0.10349	0.95377
	0.95683	-0.10265	0.27193

ROTATION ANGLES from CS0 orientation to PRINCIPAL AXES (degrees):

angles about x y z -74.087 7.353 -85.966

RADII OF GYRATION with respect to PRINCIPAL AXES:

R1 R2 R3 3.2750739e+01 4.5733776e+01 4.8875200e+01 MM

7.2. Assembly: BSM CHOP AXIS : SPIRE-BSM-020-004

VOLUME = 5.0106321e+03 MM³
 SURFACE AREA = 7.3328141e+03 MM²
 AVERAGE DENSITY = 3.1950638e-06 KILOGRAM / MM³
 MASS = 1.6009289e-02 KILOGRAM

CENTER OF GRAVITY with respect to _SPIRE-BSM-02-004 coordinate frame:
 X Y Z 0.0000000e+00 4.6417925e-01 -6.0681758e+00 MM

INERTIA with respect to SPIRE-BSM-02-004 coordinate frame: (KILOGRAM * MM²)

INERTIA TENSOR:

Ixx Ixy Ixz 6.1027583e+00 0.0000000e+00 -6.3660228e-02
 Iyx Iyy Iyz 0.0000000e+00 7.4176717e+00 5.9492677e-06
 Izx Izy Izz -6.3660228e-02 5.9492677e-06 1.7406695e+00

INERTIA at CENTER OF GRAVITY with respect to _SPIRE-BSM-02-004 coordinate frame: (KILOGRAM * MM²)

INERTIA TENSOR:

Ixx Ixy Ixz 5.5098027e+00 0.0000000e+00 -6.3660935e-02
 Iyx Iyy Iyz 0.0000000e+00 6.8281655e+00 -4.5087757e-02
 Izx Izy Izz -6.3660935e-02 -4.5087757e-02 1.7372201e+00

PRINCIPAL MOMENTS OF INERTIA: (KILOGRAM * MM²)

I1 I2 I3 1.7357470e+00 5.5108762e+00 6.8285650e+00

ROTATION MATRIX from _SPIRE-BSM-02-004 orientation to PRINCIPAL AXES:

0.01686	0.99986	0.00043
0.00885	-0.00058	0.99996
0.99982	-0.01686	-0.00886

ROTATION ANGLES from _SPIRE-BSM-02-004 orientation to PRINCIPAL AXES (degrees):

angles about x y z -90.508 0.000 -89.034

RADII OF GYRATION with respect to PRINCIPAL AXES:

R1 R2 R3 1.0412552e+01 1.8553434e+01 2.0652789e+01 MM

7.3. Assembly: Gimbal Frame : SPIRE-BSM-020-003

(Note– includes chop axis)

VOLUME = 2.7324248e+04 MM³
 SURFACE AREA = 3.5418903e+04 MM²
 AVERAGE DENSITY = 3.2306362e-06 KILOGRAM / MM³
 MASS = 8.8274705e-02 KILOGRAM

CENTER OF GRAVITY with respect to ACS2 coordinate frame:
 X Y Z 3.8892385e+00 -5.7432544e-02 4.9707259e-02 MM

INERTIA with respect to ACS2 coordinate frame: (KILOGRAM * MM²)

INERTIA TENSOR:

Ixx Ixy Ixz 4.6576925e+01 8.3785780e-01 9.1887627e-01
 Iyx Iyy Iyz 8.3785780e-01 7.7344040e+01 -2.7094953e-01
 Izx Izy Izz 9.1887627e-01 -2.7094953e-01 4.6274274e+01

INERTIA at CENTER OF GRAVITY with respect to ACS2 coordinate frame:
 (KILOGRAM * MM²)

INERTIA TENSOR:

Ixx Ixy Ixz 4.6576416e+01 8.1813998e-01 9.3594184e-01
 Iyx Iyy Iyz 8.1813998e-01 7.6008563e+01 -2.7120153e-01
 Izx Izy Izz 9.3594184e-01 -2.7120153e-01 4.4938724e+01

PRINCIPAL MOMENTS OF INERTIA: (KILOGRAM * MM²)

I1 I2 I3 4.4503068e+01 4.6987413e+01 7.6033222e+01

ROTATION MATRIX from ACS2 orientation to PRINCIPAL AXES:

-0.41747	0.90827	0.02751
0.01866	-0.02170	0.99959
0.90850	0.41782	-0.00789

ROTATION ANGLES from ACS2 orientation to PRINCIPAL AXES (degrees):

angles about x y z -90.452 1.577 -114.685

RADII OF GYRATION with respect to PRINCIPAL AXES:

R1 R2 R3 2.2453127e+01 2.3071330e+01 2.9348341e+01 MM

8. Mechanical Environment

This section outlines the interaction with the SPIRE structure mechanical environment specified in AD4.

To Be Written

9. Thermal Interface

Cooling of the BSM is provided by contact to the optical bench (per RD1) and also by a direct thermal strap, per AD4 (?).

9.1. Finish

The BSM's interface baseplate (drawing number SPIRE-BSM-020-001-002) will be aluminium alloy, grade 6082, coated with electroless nickel (nominally 10 microns) and gold (nominally 5 microns). The baseplate provides raised pads to allow the BSM to be aligned by one-off machining operations. Any such local machining may remove the gold plating and reduce the quality of thermal contact.

A thermal strap interface will also be provided directly on the BSM structural interface, (drawing number SPIRE-BSM-020-001-001) . This will comprise a tapped hole, sized M4x 4mm deep TBC. At the thermal strap interface the local area will be machined flat (TBD microns) and smooth (TBC 1.8 microns RA).

External finish requirements permitting ,the structure will be coated with electroless nickel (nominally 10 microns) and gold plated (nominally 15 microns) (TBC)

9.2. Surface Area

The contact surface area of the baseplate is 410 mm² (NB, RD1 assumes 400 mm², but does not include a thermal strap)

The contact surface area of the thermal strap is TBD mm²

9.3. Contact Force

At each contact face an approximate contact force of 1 KN (TBC) will be developed at each joint by an 8-32 UNC shoulder bolt torqued to 1.5-3.0 N-m (TBD). (NB RD1 assumes 670N)

10. Harness Routing

The BSM prime and redundant harness are separate.

Each harness includes the motor, sensor, thermometry and PCAL cables and interfaces via a fully populated 37 way MDM connector, as specified in AD5.

The harness is run to the BSM as described in AD6, with a total length of **TBD** mm and a mass of **TBD** kg.