

SPIRE INSTRUMENT

DETECTOR READOUT & CONTROL UNIT

INTERFACE CONTROL DOCUMENT

SPIRE-SAP-PRJ-000451

Contributors: **F. PINSARD-DCU Engineer**
 P. LEVACHER-MCU Engineer

	Name and Function	Date	Signature
Prepared by:	C.CARA - DRCU Responsible	14/02/03	
Checked by	J. FONTIGNIE		
Approved by:	F.PINSARD D. POULIQUEN M. MUR		
Approved by:	PA Responsible		
Approved by:	JL. AUGUERES - Project Manager		

Document change record

Issue/Revision	Date	Modified pages
0.1	18/05/2000	All: document creation - Draft
0.2	21/06/2000	§1.1 : reference documents table inserted §1.3 : Figure corrected §1.4.1 : Table 1.4.1-a updated §1.5.1 : parity suppressed §1.5.2 : parity suppressed §2.5.1 : Figures updated §2.5.2 : Figures/Table added §2.5.3 : Figure added
0.3	17/11/2000	Many: introduction of WE Summit decisions
0.4	21/06/2000	
0.5		§2.1.4.1 Command/parameter fields updated - CID11 = R/W §2.2 generic command list added S/S command list updated/added §2.3.5.2 FrameID tables added
0.6	1/03/2002	Power Profile added Power budget updated (according to RD3) S/S data format description updated: MCU trace and test added Block format updated (new position for FrameTime) Updated list of connectors Secondary power interface for DCU/MCU/SCU added/updated Thermal & mechanical interfaces with S/C added
0.7	26/06/2002	INITIAL DOCUMENT SPLITTED §2.1.1/§2.1.2 Number of fixation feet updated + figures 2.1-a + 2.1-b updated §2.2 Table updated §4.1 Reference to pin allocation table added §4.2 All tables filled according to MCU documentations + Interface Circuitry completed §4.2.7 SMEC launch Latch Confirmation removed §4.2.15 BSM Launch Latch sensor removed §4.3.4 Calibrator- Tables filled §5.1 Figure updated §5.2.1.1 Figure updated - according to SPIRE ICDs §5.2.2.1/§5.2.2.2 Figure updated - according to SPIRE ICDs §5.3 Connector List corrected §5.4.1 Shield redefined according to SPIRE HARNESS DESCRIPTION §5.4.3.1.1 Comment on shield internal connection added §5.4.3.1.2 LIA_TC module added including TC channels §5.4.3.1.3 LIA_S channel numbering corrected §5.4.3.1.4 BIAS module pin-out clarified - Added corresponding command/parameter §5.4.3.2.1 Table corrected -3V -> +3V / Launch Latch confirmation removed §5.4.3.2.2 Table corrected - launch Latch confirmation removed §5.4.3.3.1 Table updated - Signal name defined §5.4.3.3.2 Table updated - Signal name defined §6 Grounding Scheme added §7 Appendix - Internal interface: table added/corrected
1.0	14/02/2003	§2.2 power dissipation updated

		<p>§3.1.2 power profile updated §5.4.3.2.1/2 tables updated according to RD2 §7.1 Tables corrected pin 23/24/25 §5.4.3.1 shields re-connected to connector body §5.4.3.3 shields re-connected to connector body</p>
--	--	---

Distribution list

Jean-Louis AUGUÈRES	CEA	
Frederic PINSARD	CEA	
Jean FONTIGNIE	CEA	
Michel MUR	CEA	
Riccardo CERULLI	IFSI	
Renato ORFEI	IFSI	
Jerry LILIENTHAL	JPL	
Didier FERRAND	LAM	
Dominique POULIQUEN	LAM	
Patrick LEVACHER	LAM	
Ken KING	RAL	
Bruce SWINYARD	RAL	
Eric SAWYER	RAL	
Goran OLOFSSON	SO	
Hans-Gustav FLOREN	SO	

List of Acronyms

ADC	Analog to Digital Converter
AMUX	Analog Multiplexer
BSM	Beam Steering Mirror
DAC	Digital to Analog Converter
DCE	Detector Control Electronics
DCU	Detector Control Unit
DMUX	Digital Multiplexer
DPU	Data Processing Unit
DRCU	Detector Readout & Control Unit
FPU	Focal Plane Unit
FTS	Fourier Transform Spectrometer
JFET	Junction Field Effect Transistor
LIA	Lock-in amplifier
LPF	Low Pass Filter
MCE	Mechanisms Control Electronics
MCU	Mechanisms Control Unit
NA	Not Applicable
NC	Not Connected
OEP	Optical Encoder Preamplifier
PDU	Power Distribution Unit
PSU	Power Supply Unit
S/S	Sub-System
S/W	Software
SCE	Sub-system Control Electronics
SCU	Sub-system Control Unit
SMEC	Spectrometer Mechanism Control
SMPS	Switching Mode Power Supply
SNR	Signal over Noise Ratio
TBC	To Be Confirmed
TBD	To Be Defined
TBW	To Be Written
WIH	Warm Interconnect Harnesses

Table of Contents

1.	INTRODUCTION.....	9
1.1.	PURPOSE.....	9
1.2.	SCOPE.....	9
1.3.	REFERENCE DOCUMENTS	9
1.4.	APPLICABLE DOCUMENTS	9
1.5.	INTERFACES CROSS-MATRIX.....	10
2.	THERMO-MECHANICAL INTERFACES	11
2.1.	MECHANICAL INTERFACES	11
2.1.1.	<i>HSDCU unit</i>	11
2.1.2.	<i>HSFCU unit</i>	11
2.2.	THERMAL INTERFACES	11
2.2.1.	<i>HSDCU unit</i>	11
2.2.2.	<i>HSFCU unit</i>	12
3.	ELECTRICAL INTERFACES WITH S/C	15
3.1.	PCDU INTERFACE	15
3.1.1.	<i>Electrical characteristics</i>	15
3.1.2.	<i>Power profile</i>	15
4.	INTERFACE WITH FPU.....	16
4.1.	DCU INTERFACE.....	16
4.1.1.	<i>Seeing Bolometer Bias Interface</i>	16
4.1.1.1.	Electrical characteristics	16
4.1.1.2.	Interface circuitry.....	16
4.1.2.	<i>T/C Bolometer Bias Interface</i>	17
4.1.2.1.	Electrical characteristics	17
4.1.2.2.	Interface circuitry.....	17
4.1.3.	<i>JFET Vss bias interface</i>	18
4.1.3.1.	Electrical characteristics	18
4.1.3.2.	Interface circuitry.....	18
4.1.4.	<i>JFET Vdd bias interface</i>	19
4.1.4.1.	Electrical characteristics	19
4.1.4.2.	Interface circuitry.....	19
4.1.5.	<i>Heater bias interface</i>	20
4.1.5.1.	Electrical characteristics	20
4.1.5.2.	Interface circuitry.....	20
4.1.6.	<i>Photometer JFET signal interface</i>	21
4.1.6.1.	Electrical characteristics	21
4.1.6.2.	Interface circuitry.....	21
4.1.7.	<i>Spectrometer JFET signal interface</i>	22
4.1.7.1.	Electrical characteristics	22
4.1.7.2.	Interface circuitry.....	22
4.2.	MCU INTERFACE.....	23
4.2.1.	<i>SMEC Drive coil</i>	23
4.2.1.1.	Excitation.....	23
4.2.1.2.	Supply Sense	24
4.2.2.	<i>SMEC position sensor LED</i>	25
4.2.2.1.	Electrical characteristics	25
4.2.2.2.	Interface circuitry.....	25
4.2.3.	<i>SMEC position sensor photodiode</i>	26
4.2.3.1.	Electrical characteristics	26
4.2.3.2.	Interface circuitry.....	26

4.2.4.	<i>SMEC position sensor supply</i>	27
4.2.4.1.	Electrical characteristics	27
4.2.4.2.	Interface circuitry	27
4.2.5.	<i>SMEC position sensor photodiode feedback</i>	28
4.2.5.1.	Electrical characteristics	28
4.2.5.2.	Interface circuitry	28
4.2.6.	<i>SMEC launch latch supply</i>	29
4.2.6.1.	Electrical characteristics	29
4.2.6.2.	Interface circuitry	29
4.2.7.	<i>SMEC LVDT primary coil supply</i>	30
4.2.7.1.	Electrical characteristics	30
4.2.7.2.	Interface circuitry	30
4.2.8.	<i>SMEC LVDT secondary coil signal</i>	31
4.2.8.1.	Electrical characteristics	31
4.2.8.2.	Interface circuitry	31
4.2.9.	<i>Chop sensor</i>	32
4.2.9.1.	Supply	32
4.2.9.2.	Sense	33
4.2.10.	<i>Chop sensor output</i>	34
4.2.10.1.	Electrical characteristics	34
4.2.10.2.	Interface circuitry	34
4.2.11.	<i>Jiggle sensor</i>	35
4.2.11.1.	Supply	35
4.2.11.2.	Sense	36
4.2.12.	<i>Jiggle sensor output</i>	37
4.2.12.1.	Electrical characteristics	37
4.2.12.2.	Interface circuitry	37
4.2.13.	<i>BSM Launch latch coil supply</i>	38
4.2.13.1.	Electrical characteristics	38
4.2.13.2.	Interface circuitry	38
4.2.14.	<i>Chop motor</i>	39
4.2.14.1.	Supply	39
4.2.14.2.	Sense	40
4.2.15.	<i>Jiggle motor</i>	41
4.2.15.1.	Supply	41
4.2.15.2.	Sense	42
4.3.	SCU INTERFACES	43
4.3.1.	<i>Temperature Probes – “300 mK”</i>	43
4.3.1.1.	Probe bias	43
4.3.1.2.	Probe sense	44
4.3.2.	<i>Standard Temperature Probes</i>	45
4.3.2.1.	Probe bias	45
4.3.2.2.	Probe sense	47
4.3.3.	<i>Heaters</i>	49
4.3.3.1.	Sorption pump	49
4.3.3.2.	Heat switches.....	50
4.3.3.3.	Thermal Control heater	51
4.3.4.	<i>Calibrator</i>	52
4.3.4.1.	PCAL sources.....	52
4.3.4.2.	SCAL source	53
5.	CONNECTORS AND HARNESS DEFINITION	54
5.1.	OVERALL HARNESS CONFIGURATION	54
5.2.	CONNECTOR LAYOUT ON BOX	55
5.2.1.	<i>DCU box</i>	55
5.2.1.1.	Top View	55
5.2.1.2.	Lateral View	55
5.2.2.	<i>FCU box</i>	56
5.2.2.1.	Top View	56
5.2.2.2.	Lateral Views	56

5.2.3.	<i>FCU to FPU harness tail configuration</i>	57
5.3.	CONNECTOR LIST	58
5.4.	CONNECTORS DESCRIPTION	60
5.4.1.	<i>Interfaces with DPU</i>	60
5.4.2.	<i>Interfaces with S/C</i>	66
5.4.3.	<i>Interfaces with FPU</i>	67
5.4.3.1.	DCU Interfaces.....	67
5.4.3.2.	MCU Interfaces.....	85
5.4.3.3.	SCU Interfaces	91
6.	GROUNDING SCHEME	101
7.	APPENDIX – DRCU SUB-SYSTEM INTERCONNECTIONS	102
7.1.	PSU TO DCU INTERFACE	102
7.2.	PSU TO MCU INTERFACE	106
7.3.	PSU TO SCU INTERFACE.....	110

1. Introduction

1.1. Purpose

The purpose of this document is to provide a description of all the DRCU units' electrical interfaces. Along with the DRCU Mechanical ICD this document shall allow a complete overview of the DRCU units in terms of interfaces. This document will be useful when performing unit test, integration or qualification by containing all the DRCU electrical interfaces (this avoids the need for multiple documents).

1.2. Scope

The scope of this document includes all the DRCU units external interfaces low-level description including electrical and low level protocol and connector pin-out. However in the case of the analog interfaces with FPU the description is limited to pin-out since these interfaces are already described in respective sub-system ICDs.

1.3. Reference Documents

RD1	Note IFSI : <i>DPU/DRCU Interfaces</i>	SP-RCI-18.5.00
RD2	MCU interconnections list	LAM/ELE/FTS/NTT/010314 - issue 3.0

1.4. Applicable Documents

AD1	Herschel/Planck IID part A	SCI-PT-IIDA-04624
AD2	Herschel/SPIRE IID part B	SCI-PT-IIBD-02124
AD3	SPIRE HARNESS DEFINITION	SPIRE-RAL-PRJ-000608

1.5. Interfaces cross-matrix

This table lists the interface types against the SPIRE sub-assembly for the HSDCU and HSFCU units.

Unit	Interface Types	Interfaces with:
HSDCU	Electrical – Digital	DPU
	Electrical – Analog	FPU
	Mechanical	S/C
	Thermal	S/C
HSFCU	Electrical – Digital	DPU
	Electrical – Analog	FPU
	Electrical - Power	S/C DCU
	Mechanical	S/C
	Thermal	S/C

2. Thermo-mechanical Interfaces

2.1. Mechanical interfaces

2.1.1. HSDCU unit

Assuming the HSDCU unit occupies a rectangular volume defined by its surface, its height and its mass can summarize the mechanical interface:

- 490 mm x 285 mm
- 305 mm
- 15.67 kg

Mounting on the S/C is done by means of 12 feet and fastening by means of 12 M4 screws.

For a fully detailed mechanical interface description refers to the figure 2.-a.

2.1.2. HSFCU unit

Assuming the HSFCU unit occupies a rectangular volume defined by its surface, its height and its mass can summarize the mechanical interface:

- 370 mm x 325 mm
- 336 mm
- 15.28 kg

Mounting on the S/C is done by means of 12 feet and fastening by means of 12 M4 screws.

For a fully detailed mechanical interface description refers to the figure 2.-b.

2.2. Thermal interfaces

2.2.1. HSDCU unit

The thermal is defined by the dissipated power by the unit and the parameters, which define the heat exchange (by radiation and conduction) with its environment.

The parameters for heat exchange dimensioning are:

Dissipated Power (W)	Radiation Surfaces	Surfaces Emissivity	Contact Surfaces
33.2 - Photometer 16.0 - Spectrometer	See §2.1.1	> 0.85	28180 mm ²

2.2.2. HSFCU unit

The thermal is defined by the dissipated power by the unit and the parameters, which define the heat exchange (by radiation and conduction) with its environment.

The parameters for heat exchange dimensioning are:

Dissipated Power (W)	Radiation Surfaces	Surfaces Emissivity	Contact Surfaces
47.6 - Photometer 40.3 - Spectrometer	See §2.1.2	> 0.85	100655 mm ²

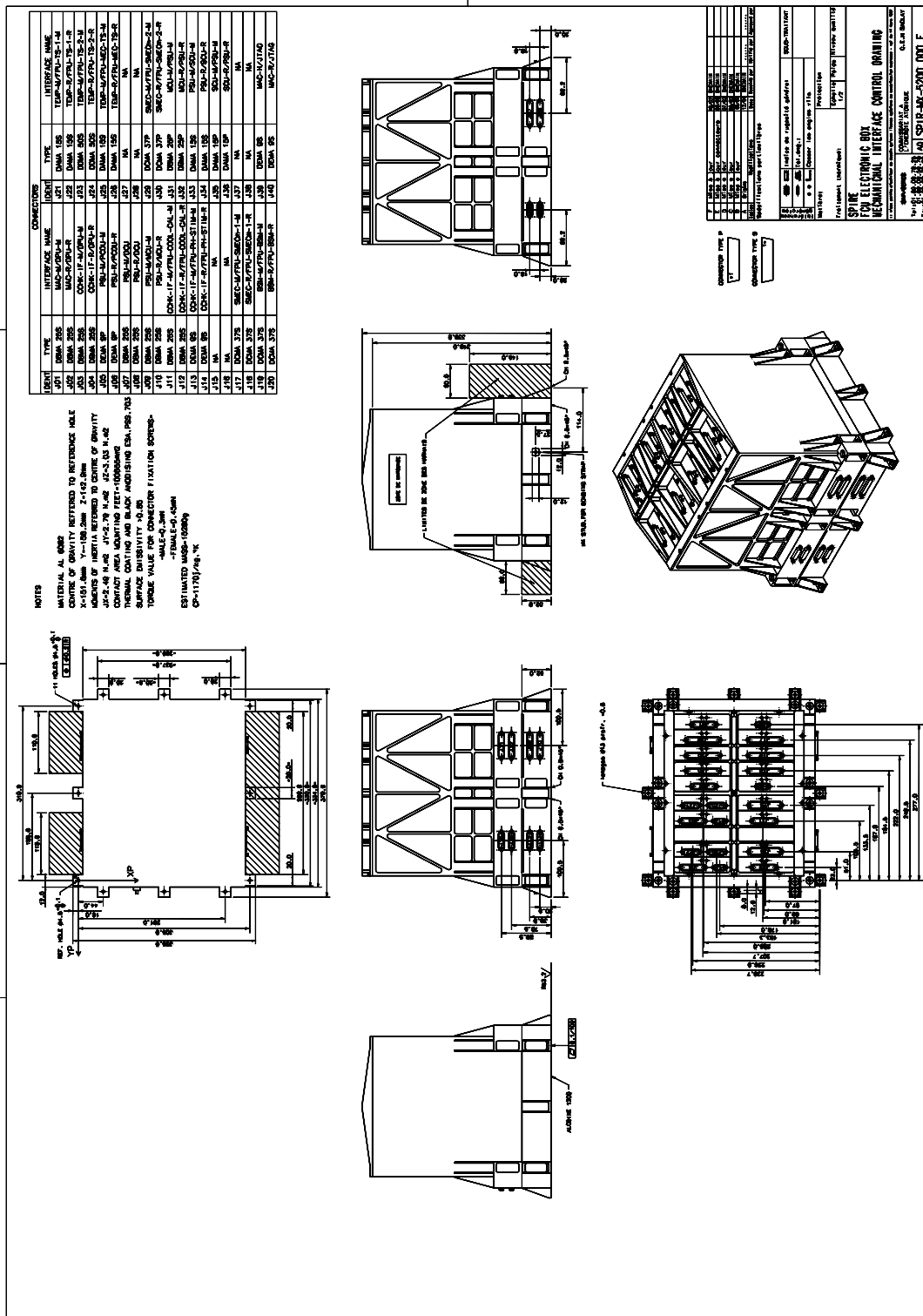

Figure 2.-b FCU mechanical ICD

3. Electrical interfaces with S/C

Electrical interfaces with the S/C are limited to primary power distribution. It corresponds to a main and redundant interface between the PCDU ports and the DRCU power supply modules (PSU).

3.1. PCDU interface

3.1.1. Electrical characteristics

The following table gives a summary of this interface:

Connector Id(s)	HS_FCU_J05 HS_FCU_J06
Pin number(s)	2, 7
Interface type	Input
Signal type	DC voltage
Voltage range (nominal)	26 to 29 V
Voltage range (operating)	0 to 35 V
Maximum Power (average)	80.8 W
Current range	See Power Profile §3.1.2
Reference pin(s) (return line)	4, 8
Corresponding command(s)	NA
Source impedance ¹	< 200 mΩ for f < 1kHz ≤ 50 Ω for f > 1MHz

- Average power is estimated according to definition from AD1 §5.9.5.6.1.
- For further dynamic performance refer to AD1 §5.9.5.

3.1.2. Power profile

Mode	Power Consumption (W)	Comment
Observing Photometer (average)	80.8	Nominal operation
Observing Spectrometer (average)	56.3	Nominal operation
Recycling (SCU on only)	34.51 (tbc)	Nominal operation
Stand-by (SCU on only)	33.88 (tbc)	Nominal operation
MCU boot	38.34 (tbc)	DRCU power on (INIT mode)

¹ See LISN characteristics (AD1 §9.5.6.9) for detailed description

4. Interface with FPU

The DRCU units interface with the FPU by means of a large number of analog interfaces. Those interfaces are related to the detector, mechanism, cooler, calibrators and thermometer sub-systems respectively.

4.1. DCU interface

4.1.1. Seeing Bolometer Bias Interface

The bolometer bias interface consists of 5 individual balanced ports has described here after.

4.1.1.1. Electrical characteristics

Connector Id(s)	HSDCU_J29 to HSDCU_J32
Pin number(s)	See pin allocation tables §5.4.3.1.4 Signal Names: Pbias_xxxx
Interface type	Output
Signal type	AC voltage
Voltage Range	0 to 200 mV rms
Current range	0 to 3.3 μ A rms
Transmission mode	Balanced/Collective shield
Reference pin(s) (return line)	See pin allocation tables §5.4.3.1.4 Signal Names: Nbias_xxxx
Source impedance	< 4 k Ω
Load impedance (range)	\geq 60 k Ω // 1 nF
AC characteristics	
Waveform	Sine
Frequency	50 – 300 Hz
Transition Time	NA
Corresponding command(s) <i>Photometer:</i>	SetPhotoBiasFreq SetPhotoBiasAmpl
Corresponding command(s) <i>Spectrometer:</i>	SetSpectroBiasFreq SetSpectroBiasAmpl

4.1.1.2. Interface circuitry

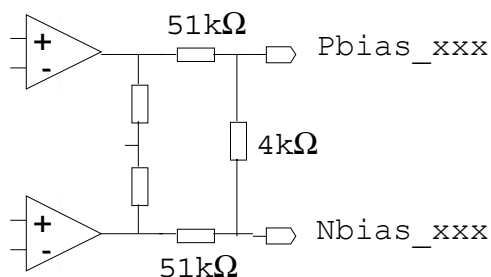

4.1.2. T/C Bolometer Bias Interface

4.1.2.1. Electrical characteristics

Connector Id(s)	HSDCU_J31 & HSDCU_J32
Pin number(s)	1
Interface type	Output
Signal type	AC voltage
Voltage Range	0 to 500 mV rms
Current range	0 to 1 μ A rms
Transmission mode	Balanced / Collective shield
Reference pin(s) (return line)	20
Source impedance	< 4 k Ω
Load impedance (range)	\geq 3 M Ω // 1 nF
AC characteristics	
Waveform	Sine
Frequency	50 – 300 Hz
Transition Time	NA
Corresponding command(s)	SetPhotoBiasFreq SetPhotoBiasAmpl

4.1.2.2. Interface circuitry

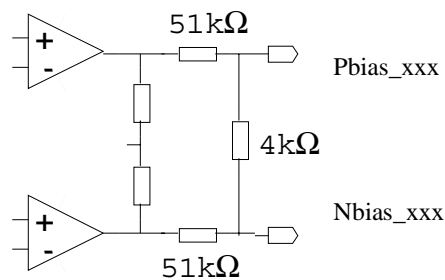

4.1.3. JFET Vss bias interface

4.1.3.1. Electrical characteristics

Connector Id(s)	HSDCU_J29 to HSDCU_J32
Pin number(s)	See pin allocation tables §5.4.3.1.4: Signal names: Vssx_P/Vssx_S
Interface type	Output
Signal type	DC voltage
Voltage Range	0 to -5 V
Current range	0 to 5 mA
Transmission mode	Single
Reference pin(s) (return line)	See pin allocation tables §5.4.3.1.4 Signal Name: Gnd_Bias_Ph/Gnd_Bias_Sp
Source impedance	10 Ω
Load impedance (range)	NA
Corresponding command(s) <i>Photometer:</i>	SetPhotoJfetVss SetPhotoJfetPWR
Corresponding command(s) <i>Spectrometer:</i>	SetSpectroJfetVss SetSpectroJfetPWR

4.1.3.2. Interface circuitry

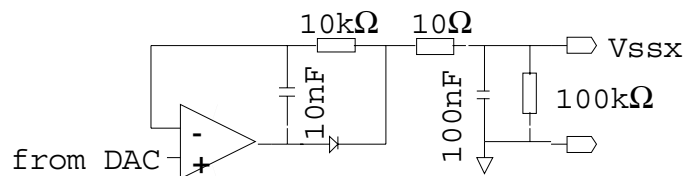

4.1.4. JFET Vdd bias interface

4.1.4.1. Electrical characteristics

Connector Id(s)	HSDCU_J29 to HSDCU_J32
Allocated pin(s)	See pin allocation tables §5.4.3.1.4: Signal names: Vddx_P/Vddx_S
Interface type	Output
Signal type	DC voltage
Voltage Range	1.5 to 4 V (adjusted by design)
Current range	0 to 5 mA
Transmission mode	Single
Reference pin(s) (return line)	See pin allocation tables §5.4.3.1.4 Signal Name: Gnd_Bias_Ph/Gnd_Bias_Sp
Source impedance	10 Ω
Load impedance (range)	
Corresponding command(s)	NA
Corresponding command(s) <i>Photometer:</i>	SetPhotoJfetPWR
Corresponding command(s) <i>Spectrometer:</i>	SetSpectroJfetPWR

4.1.4.2. Interface circuitry

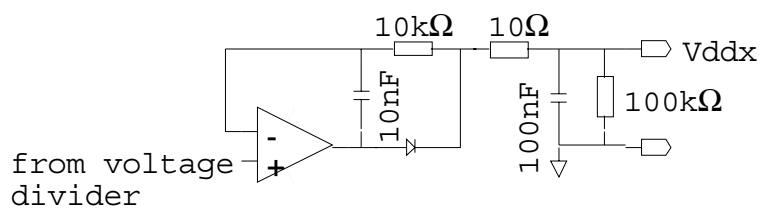

4.1.5. Heater bias interface

4.1.5.1. Electrical characteristics

Connector Id(s)	HS_DCU_J29 to HS_DCU_J32
Allocated pin(s)	See pin allocation tables §5.4.3.1.4: Signal names: Nheater_XXX
Interface type	Output
Signal type	DC voltage
Voltage Range: <i>Photometer</i>	0 to 5 V
Voltage Range: <i>Spectrometer</i>	0 to 3 V
Current range: <i>Photometer</i>	0 to 25 mA
Current Range: <i>Spectrometer</i>	0 to 10 mA
Transmission mode	Single
Reference pin(s) (return line)	See pin allocation tables §5.4.3.1.4: Signal names: Gnd_Bias_Ph/Gnd_Bias_Sp
Source impedance	NA
Load impedance (range)	200 Ω / 300 Ω
Corresponding command(s) <i>Photometer</i>	SetSpectroHeaterPWR
Corresponding command(s) <i>Spectrometer</i>	SetPhotoHeaterPWR

4.1.5.2. Interface circuitry

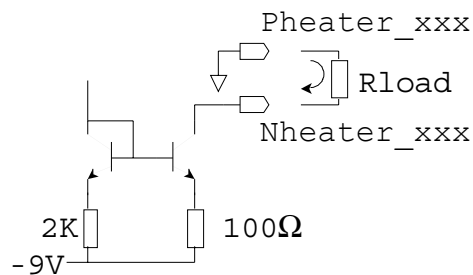

4.1.6. Photometer JFET signal interface

4.1.6.1. Electrical characteristics

Connector Id(s)	HSDCU_J05 to HSDCU_J22
Allocated pin(s)	See §5.4.3.1.1/5.4.1.2 Signal names: Channel x +
Interface type	Input
Signal type	AC voltage + DC offset
Voltage range	0 to 11 mV rms
Transmission mode	Balanced
Reference pin(s) (return line)	See §5.4.3.1. 1/5.4.1.2 Signal names: Channel x -
Source impedance	7 k Ω
Load impedance	1 M Ω @ +1 V DC offset
AC characteristics	
Waveform	Sine
Frequency	50 – 300 Hz
Transition Time	NA
Corresponding command(s)	NA

4.1.6.2. Interface circuitry

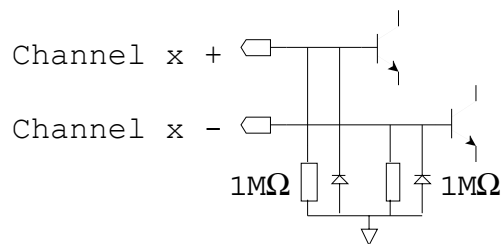

4.1.7. Spectrometer JFET signal interface

4.1.7.1. Electrical characteristics

Connector Id(s)	HSDCU_J23 to HSDCU_J28
Allocated pin(s)	See §5.4.3.1.3 Signal names: Channel x +
Interface type	Input
Signal type	AC voltage + DC offset
Voltage range	0 to 17 mV rms
Transmission mode	Balanced
Reference pin(s) (return line)	See §5.4.3.1.3 Signal names: Channel x -
Source impedance	7 k Ω
Load impedance	1 M Ω @ +1 V DC offset
AC characteristics	
Waveform	Sine
Frequency	50 – 300 Hz
Transition Time	NA
Corresponding command(s)	NA

4.1.7.2. Interface circuitry

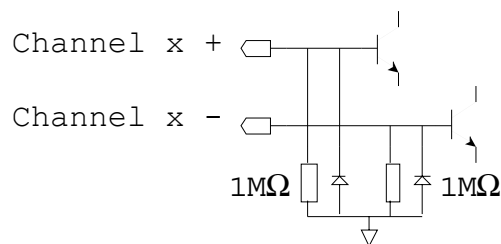

4.2. MCU interface

4.2.1. SMEC Drive coil

4.2.1.1. Excitation

4.2.1.1.1. Electrical characteristics

Connector Id(s)	HSFCU_J17 HSFCU_J18
Allocated pin(s)	1, 21
Interface type	Output
Signal type	AC current
Current range	0 to 100 mA
Transmission mode	Differential
Reference pin(s) (return line)	2, 22
Source impedance	NA
Load impedance	
AC characteristics	
Waveform	Saw tooth Steps
Frequency	
Transition Time	
Corresponding command(s)	SetMotorMode SetSTrajMode SetSScanSpeed

4.2.1.1.2. Interface circuitry

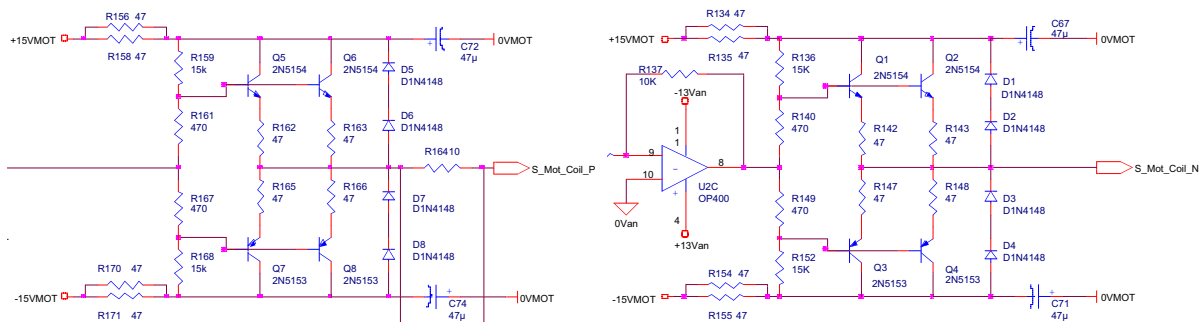

4.2.1.2. Supply Sense

4.2.1.2.1. Electrical characteristics

Connector Id(s)	HSFCU_J17 HSFCU_J18
Allocated pin(s)	4
Interface type	Input
Signal type	AC voltage
Voltage range	
Transmission mode	Differential
Reference pin(s) (return line)	5
Source impedance	
Load impedance	
AC characteristics	
Waveform	Sawtooth Steps
Frequency	
Transition Time	
Corresponding command(s)	NA

4.2.1.2.2. Interface circuitry

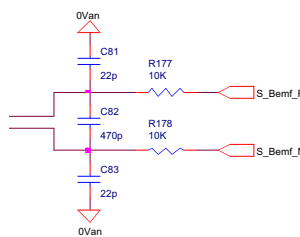

4.2.2. SMEC position sensor LED

4.2.2.1. Electrical characteristics

Connector Id(s)	HSFCU_J17 HSFCU_J18
Allocated pin(s)	7
Interface type	Output
Signal type	DC current
Current range	0 to 1 mA
Transmission mode	Single
Reference pin(s) (return line)	8
Source impedance	< 6 k Ω
Load impedance	NA
Corresponding command	SetSEncoderPWR

4.2.2.2. Interface circuitry

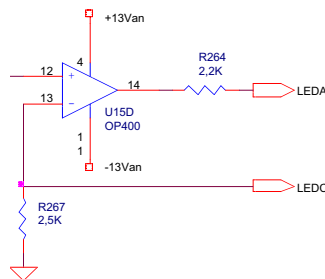

4.2.3. SMEC position sensor photodiode

4.2.3.1. Electrical characteristics

Connector Id(s)	HSFCU_J17 HSFCU_J18
Allocated pin(s)	10, 13, 16
Interface type	Input
Signal type	DC+AC current
Current range	
Transmission mode	Differential
Reference pin(s) (return line)	11, 14, 17
Source impedance	NA
Load impedance	330 k Ω
AC characteristics	
Waveform	Sine
Frequency	
Transition Time	NA
Corresponding command(s)	NA

4.2.3.2. Interface circuitry

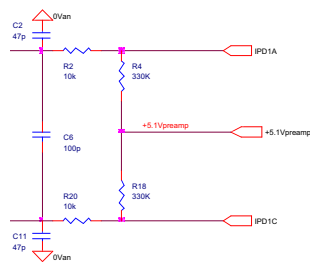

4.2.4. SMEC position sensor supply

4.2.4.1. Electrical characteristics

Connector Id(s)	HSFCU_J17 HSFCU_J18
Allocated pin(s)	27
Interface type	Output
Signal type	DC voltage
Voltage range	-3.00 ± 0.05 V
Current range	1 mA
Transmission mode	Single
Reference pin(s) (return line)	28
Source impedance	≤ 2 k Ω
Load impedance	NA
Corresponding command(s)	SetSEncoderPWR

4.2.4.2. Interface circuitry

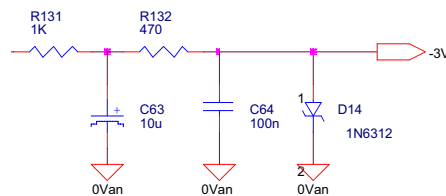

4.2.5. SMEC position sensor photodiode feedback

4.2.5.1. Electrical characteristics

Connector Id(s)	HSFCU_J17 HSFCU_J18
Allocated pin(s)	30, 33, 36
Interface type	Output
Signal type	DC voltage
Voltage range	
Current range	
Transmission mode	Differential
Reference pin(s) (return line)	31, 34, 37
Source impedance	
Load impedance	NA
Corresponding command(s)	SetSEncoderPWR

4.2.5.2. Interface circuitry



4.2.6. SMEC launch latch supply

4.2.6.1. Electrical characteristics

Connector Id(s)	HSFCU_J29 HSFCU_J30
Allocated pin(s)	1, 24
Interface type	Output
Signal type	AC current
Voltage range	0 to 27 V
Current range	0 to 400 mA
Transmission mode	Differential
Reference pin(s) (return line)	2, 25
Source impedance	NA
Load impedance	
AC characteristics	
Waveform	Pulse
Active Duration	50 ms
Transition Time	
Corresponding command(s)	SetSLaunchLatch

4.2.6.2. Interface circuitry

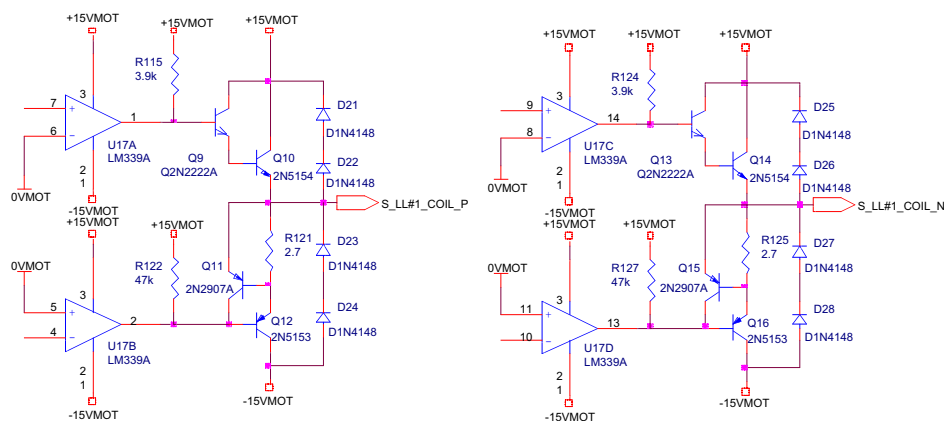

4.2.7. SMEC LVDT primary coil supply

4.2.7.1. Electrical characteristics

Connector Id(s)	HSFCU_J29 HSFCU_J30
Allocated pin(s)	13
Interface type	Output
Signal type	AC voltage
Voltage range	?
Current range	5 mA
Transmission mode	Differential
Reference pin(s) (return line)	14
Source impedance	500 Ω (AC)
Load impedance	
AC characteristics	
Waveform	Sine
Frequency	10 000 Hz
Transition Time	NA
Corresponding command(s)	SetSLVDTPWR

4.2.7.2. Interface circuitry

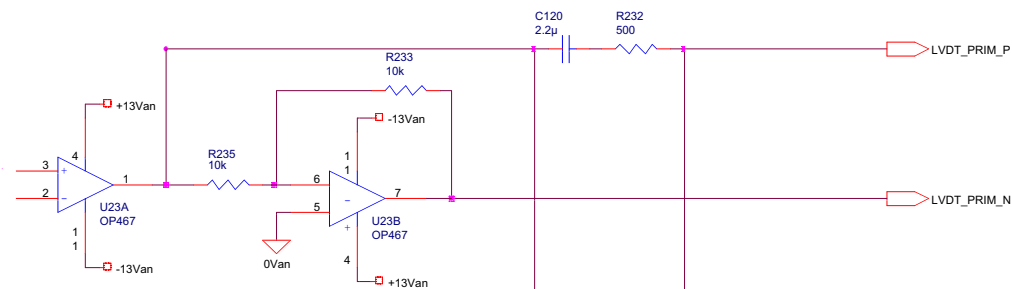

4.2.8. SMEC LVDT secondary coil signal

4.2.8.1. Electrical characteristics

Connector Id(s)	HSFCU_J29 HSFCU_J30
Allocated pin(s)	15, 17
Interface type	Input
Signal type	AC voltage
Voltage range	
Current range	50 μ A
Transmission mode	Differential
Reference pin(s) (return line)	16, 18
Source impedance	
Load impedance	
AC characteristics	
Waveform	Sine Sine Burst
Frequency	
Transition Time	NA
Corresponding command(s)	SetSLVDTPWR SetSScanSpeed SetSTrajMode

4.2.8.2. Interface circuitry

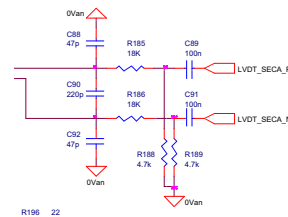

4.2.9. Chop sensor

4.2.9.1. Supply

4.2.9.1.1. Electrical characteristics

Connector Id(s)	HSFCU_J19 HSFCU_J20
Allocated pin(s)	1
Interface type	Output
Signal type	DC voltage
Voltage range	
Current range	1 mA
Transmission mode	Single
Reference pin(s) (return line)	20
Source impedance	
Load impedance	
Corresponding command(s)	SetCSensorPWR

4.2.9.1.2. Interface circuitry

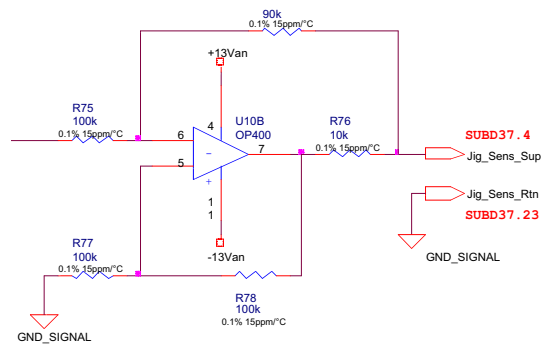

4.2.9.2. Sense

4.2.9.2.1. Electrical characteristics

Connector Id(s)	HSFCU_J19 HSFCU_J20
Allocated pin(s)	2
Interface type	Input
Signal type	DC voltage
Voltage range	0 to 0.4 V
Transmission mode	Single
Reference pin(s) (return line)	3
Source impedance	
Load impedance	
Corresponding command(s)	NA

4.2.9.2.2. Interface circuitry

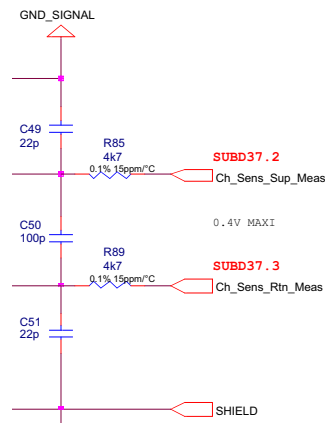

4.2.10. Chop sensor output

4.2.10.1. Electrical characteristics

Connector Id(s)	HSFCU_J19 HSFCU_J20
Allocated pin(s)	21
Interface type	Input
Signal type	AC signal
Voltage range	0 to 0.4 V
Transmission mode	Single
Reference pin(s) (return line)	3
Source impedance	
Load impedance	
AC characteristics	
Waveform	Saw Tooth Square Steps
Frequency	0 to 5 Hz
Transition Time	
Corresponding command(s)	NA

4.2.10.2. Interface circuitry

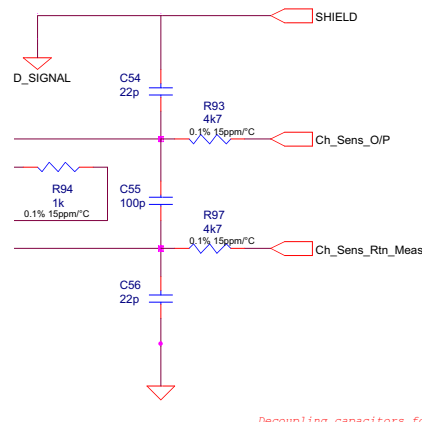

4.2.11. Jiggle sensor

4.2.11.1. Supply

4.2.11.1.1. Electrical characteristics

Connector Id(s)	HSFCU_J19 HSFCU_J20
Allocated pin(s)	4
Interface type	Output
Signal type	DC voltage
Voltage range	0.4 V
Transmission mode	Single
Current range	0 to 1 mA
Reference pin(s) (return line)	23
Source impedance	
Load impedance	
Corresponding command(s)	SetJSensorPWR

4.2.11.1.2. Interface circuitry

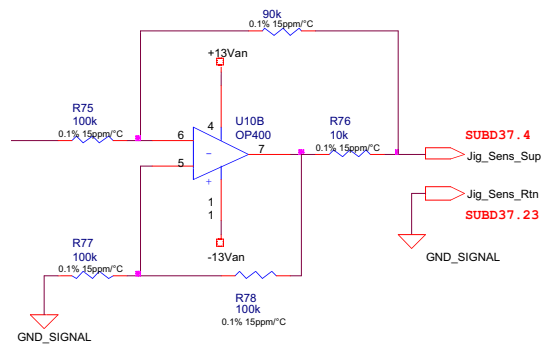

4.2.11.2. Sense

4.2.11.2.1. Electrical characteristics

Connector Id(s)	HSFCU_J19 HSFCU_J20
Allocated pin(s)	5
Interface type	Input
Signal type	DC voltage
Voltage range	0 to 0.4 V
Transmission mode	Differential
Reference pin(s) (return line)	6
Source impedance	
Load impedance	
Corresponding command(s)	NA

4.2.11.2.2. Interface circuitry

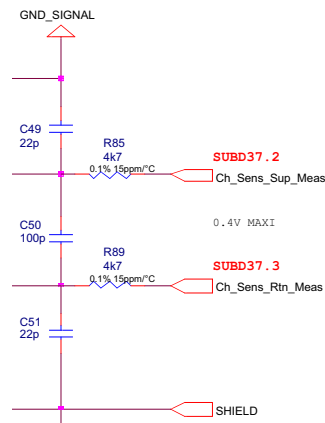

4.2.12. Jiggle sensor output

4.2.12.1. Electrical characteristics

Connector Id(s)	HSFCU_J19 HSFCU_J20
Allocated pin(s)	24
Interface type	Input
Signal type	AC signal
Voltage range	0 to 0.4 V
Transmission mode	Differential
Reference pin(s) (return line)	6
Source impedance	
Load impedance	
AC characteristics	
Waveform	Saw Tooth Square Steps
Frequency	0 to 5 Hz
Transition Time	
Corresponding command(s)	NA

4.2.12.2. Interface circuitry

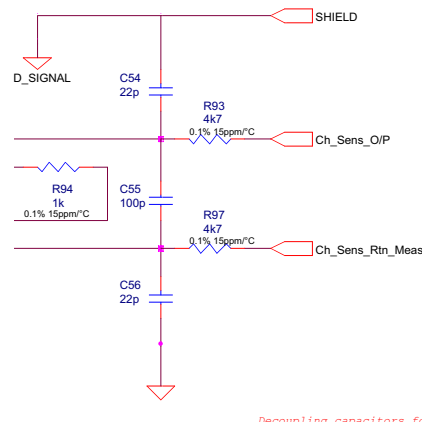

4.2.13. BSM Launch latch coil supply

4.2.13.1. Electrical characteristics

Connector Id(s)	HSFCU_J19 HSFCU_J20
Allocated pin(s)	13
Interface type	Output
Signal type	AC voltage
Voltage range	0 to 27 V
Current range	0 to 400 mA
Transmission mode	Differential
Reference pin(s) (return line)	14
Source impedance	
Load impedance	
AC characteristics	
Waveform	Pulse
Active Duration	50 ms
Transition Time	
Corresponding command(s)	SetBSMLaunchLatch

4.2.13.2. Interface circuitry

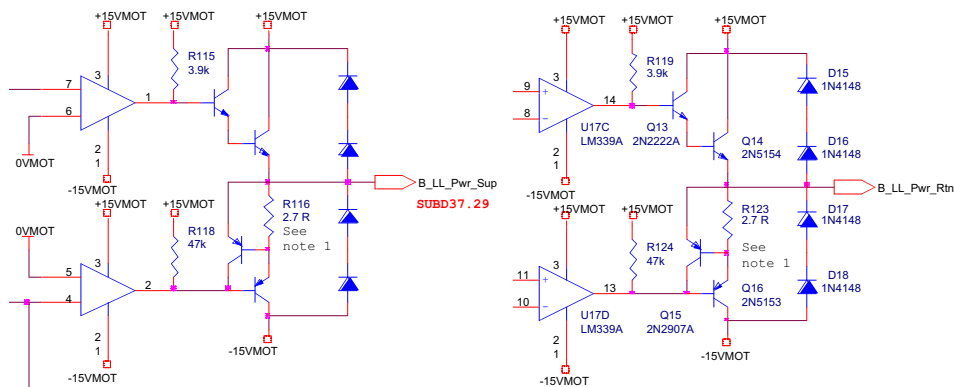

4.2.14. Chop motor

4.2.14.1. Supply

4.2.14.1.1. Electrical characteristics

Connector Id(s)	HSFCU_J19 HSFCU_J20
Allocated pin(s)	15
Interface type	Output
Signal type	AC voltage
Voltage range	0 to ± 13 V
Current range	0 to 40 mA
Transmission mode	Single
Reference pin(s) (return line)	34
Source impedance	
Load impedance	
AC characteristics	
Waveform	Saw Tooth Steps
Frequency	0 to 5 Hz
Transition Time	
Corresponding command(s)	SetChopMode SetChopNumber SetCPosition0 SetCPosition1 SetChopPeriod

4.2.14.1.2. Interface circuitry

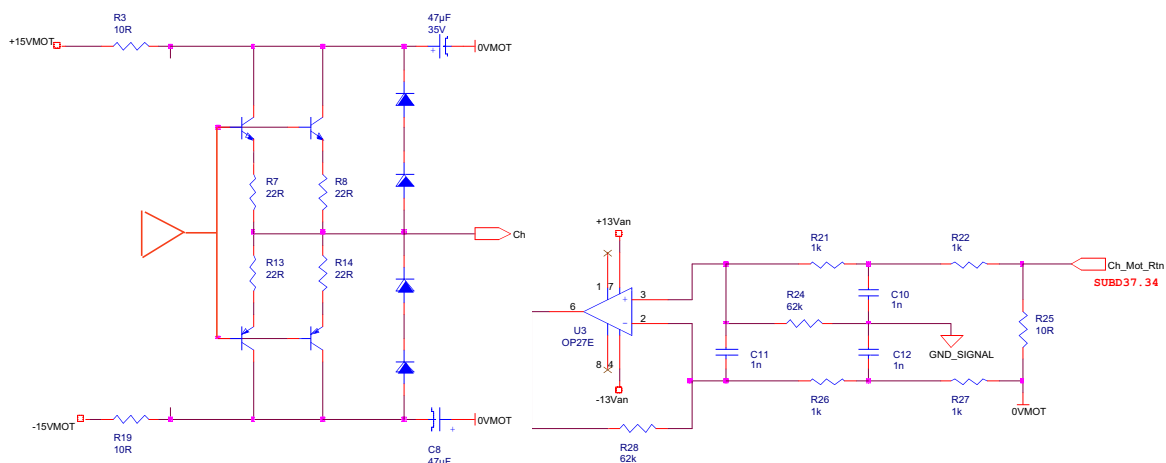

4.2.14.2. Sense

4.2.14.2.1. Electrical characteristics

Connector Id(s)	HSFCU_J19 HSFCU_J20
Allocated pin(s)	16
Interface type	Input
Signal type	AC voltage
Voltage range	0 to 15 V
Transmission mode	Diferential
Reference pin(s) (return line)	35
Source impedance	
Load impedance	
AC characteristics	
Waveform	Saw Tooth Steps
Frequency	0 to 5 Hz
Transition Time	
Corresponding command(s)	NA

4.2.14.2.2. Interface circuitry

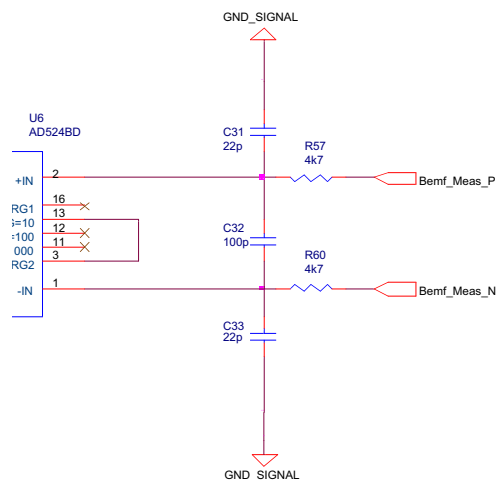

4.2.15. Jiggle motor

4.2.15.1. Supply

4.2.15.1.1. Electrical characteristics

Connector Id(s)	HSFCU_J19 & HSFCU_J20
Allocated pin(s)	36
Interface type	Output
Signal type	AC voltage
Voltage range	0 to ± 13 V
Current range	0 to 40 mA
Transmission mode	
Reference pin(s) (return line)	18
Source impedance	
Load impedance	
AC characteristics	
Waveform	Saw Tooth Square Steps
Frequency	0 to 5 Hz
Transition Time	
Corresponding command(s)	SetJigMode SetJigNumber SetJPosition0 SetJPosition1 SetJigPeriod

4.2.15.1.2. Interface circuitry

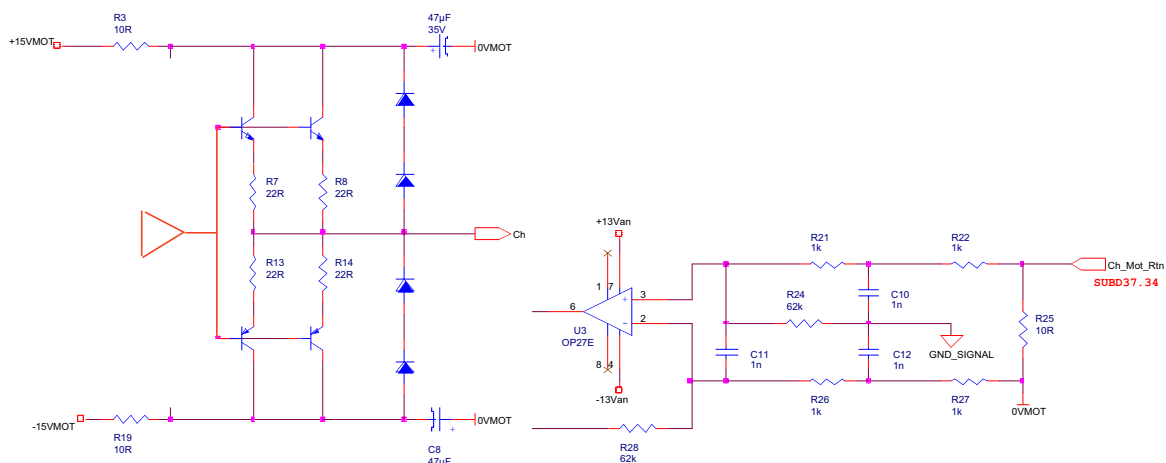

4.2.15.2. Sense

4.2.15.2.1. Electrical characteristics

Connector Id(s)	HSFCU_J19 HSFCU_J20
Allocated pin(s)	37
Interface type	Input
Signal type	AC voltage
Voltage range	0 to 15 V
Transmission mode	Differential
Reference pin(s) (return line)	19
Source impedance	
Load impedance	
AC characteristics	
Waveform	Saw Tooth Square Steps
Frequency	0 to 5 Hz
Transition Time	
Corresponding command(s)	NA

4.2.15.2.2. Interface circuitry

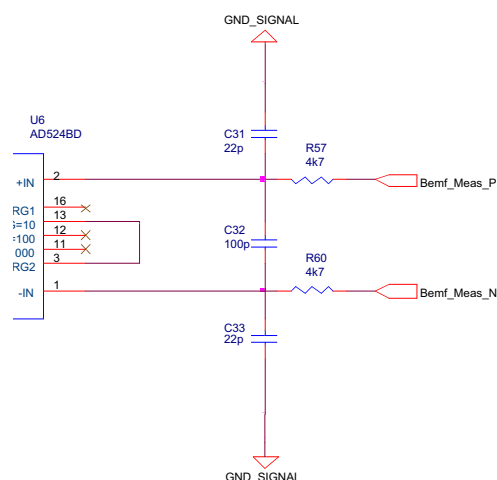

4.3. SCU interfaces

4.3.1. Temperature Probes – “300 mK”

This interface is a 4-wire input/output type as described bellow:

4.3.1.1. Probe bias

4.3.1.1.1. Electrical characteristics

Connector Id(s)	HSFCU_J23 HSFCU_J24
Allocated pin(s)	1
Interface type	Output
Signal type	AC current
Current range	0 / 40nA
Transmission mode	Balanced
Reference pin(s) (return lines)	2
Source impedance	4.7 M Ω
Load impedance	100 Ω to 150 k Ω
AC characteristics	
Waveform	Square
Frequency	20 Hz
Transition Time	< 1 ms
Corresponding command(s)	SetSubKOnOff

4.3.1.1.2. Interface circuitry

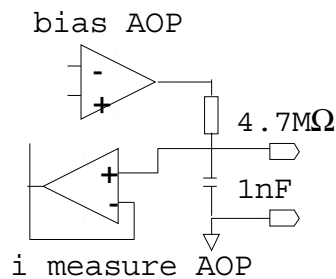

4.3.1.2. Probe sense

4.3.1.2.1. Electrical characteristics

Connector Id(s)	HSFCU_J23 HSFCU_J24
Pin number(s)	18
Interface type	Input
Signal type	AC voltage
Voltage range	0 to 6 m V _{pp}
Transmission mode	Balanced
Reference pin(s) (return line)	35
Load impedance	> 1 M Ω
Corresponding command(s)	NA

4.3.1.2.2. Interface circuitry

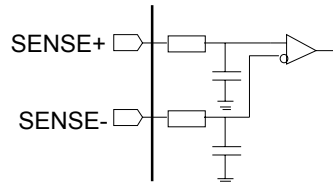

4.3.2. Standard Temperature Probes

This interface is a 4-wire input/output type as described bellow:

4.3.2.1. Probe bias

4.3.2.1.1. *Electrical characteristics*

Connector Id(s)	HSFCU_J21 HSFCU_J22
Pin number(s)	1, 4, 6
Interface type	Output
Signal type	DC voltage
Voltage	0 / 20 mV
Current range	0-200 μ A
Transmission mode	Single
Reference pin (return line)	2, 5, 7
Source impedance	
Load impedance	100 Ω - 100k Ω
Corresponding command(s)	SetTempOnOff

Connector Id(s)	HSFCU_J23 HSFCU_J24
Pin number(s)	3, 4, 6, 7, 9, 10, 12, 13, 15, 16
Interface type	Output
Signal type	DC voltage
Voltage	0 / 20 mV
Current range	0-200 μ A
Transmission mode	Single
Reference pin (return line)	19, 5, 22, 8, 25, 11, 28, 14, 31, 17
Source impedance	
Load impedance	100 Ω - 100k Ω
Corresponding command(s)	SetTempOnOff

Connector Id(s)	HSFCU_J25 HSFCU_J26
Pin number(s)	1, 4, 6
Interface type	Output
Signal type	DC voltage
Voltage	0 / 20 mV
Current range	0-200 μ A
Transmission mode	Single
Reference pin (return line)	9, 11, 14
Source impedance	
Load impedance	100 Ω - 100k Ω
Corresponding command(s)	SetTempOnOff

4.3.2.1.2. *Interface circuitry*

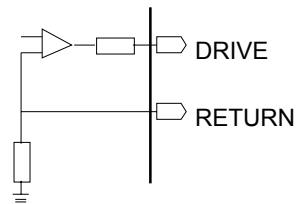

4.3.2.2. Probe sense

4.3.2.2.1. Electrical characteristics

Connector Id(s)	HSFCU_J21 HSFCU_J22
Pin number(s)	9, 11, 14
Interface type	Input
Signal type	DC current
Current range	0 to 200 μ A
Transmission mode	Balanced
Reference pin(s) (return line)	10, 12, 15
Load impedance	$\geq 1 \text{ M}\Omega$

Connector Id(s)	HSFCU_J23 HSFCU_J24
Pin number(s)	20, 21, 23, 24, 26, 27, 29, 30, 32, 33
Interface type	Input
Signal type	DC current
Current range	0 to 200 μ A
Transmission mode	Balanced
Reference pin(s) (return line)	36, 37, 39, 40, 42, 44, 45, 47, 48, 50
Load impedance	$\geq 1 \text{ M}\Omega$

Connector Id(s)	HSFCU_J25 HSFCU_J26
Pin number(s)	2, 5, 7
Interface type	Input
Signal type	DC Current
Current range	0 to 200 μ A
Transmission mode	Balanced
Reference pin(s) (return line)	10, 12, 15
Load impedance	$\geq 1 \text{ M}\Omega$

4.3.2.2.2. *Interface circuitry*

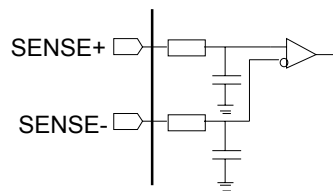

4.3.3. Heaters

4.3.3.1. Sorption pump

4.3.3.1.1. Electrical characteristics

Connector Id(s)	HSFCU_J11 HSFCU_J12
Pin number(s)	1/2*
Interface type	Output
Signal type	DC current
Current range	0 to 35 mA
Short circuit current	100 mA
Voltage range	0 to +15 V
Load impedance	402 Ω
Transmission mode	Balanced
Reference pin(s) (return lines)	14/15*
Source impedance	
Corresponding command(s)	SetSPHeaterB

* Double wires interface.

4.3.3.1.2. Interface circuitry

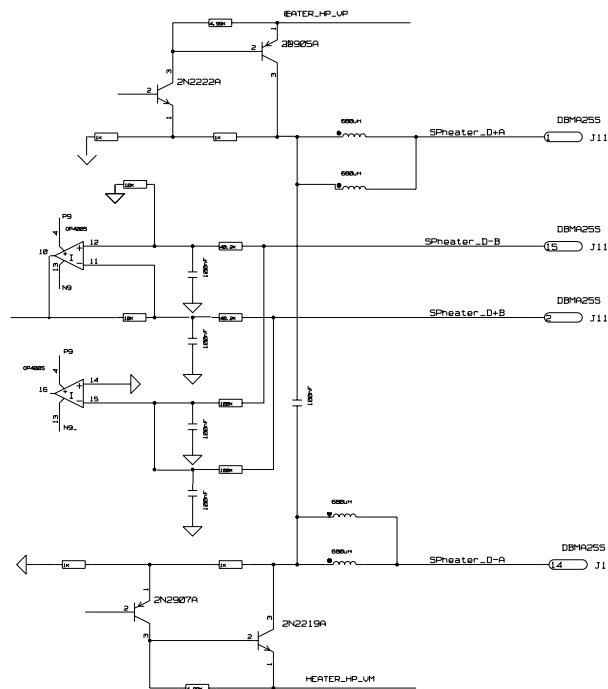

4.3.3.2. Heat switches

4.3.3.2.1. Electrical characteristics

Connector Id(s)	HSFCU_J11 HSFCU_J12
Pin number(s)	3/4, 5/6*
Interface type	Output
Signal type	DC current
Current range	0 to 2 mA
Voltage range	0 to 9 V
Transmission mode	Balanced
Reference pin(s) (return line)	16/17, 18/19*
Load impedance	402 Ω
Corresponding command(s)	SetSPHSHeatB SetEVHSHeatB

* Double wires interface.

4.3.3.2.2. Interface circuitry

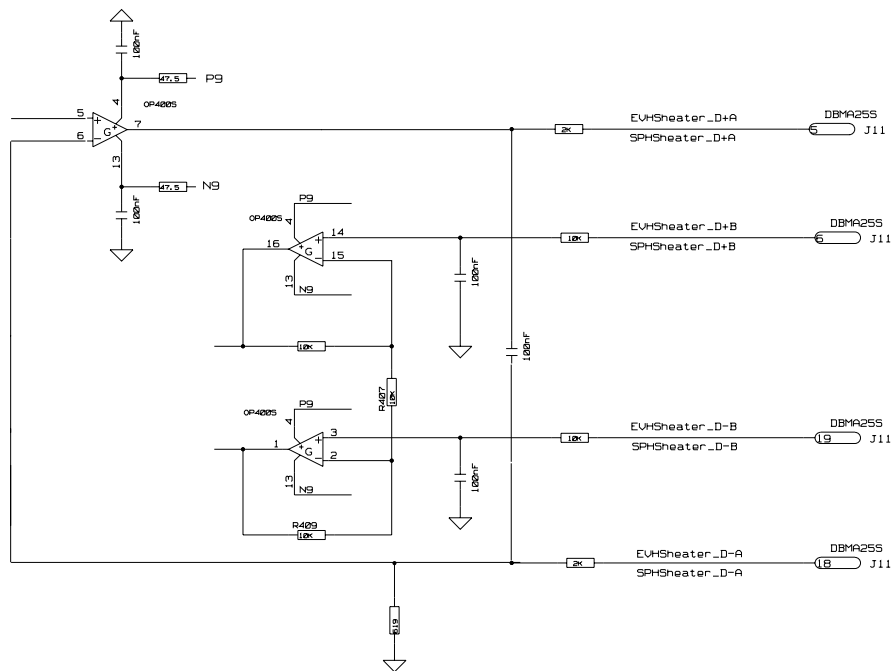

4.3.3.3. Thermal Control heater

4.3.3.3.1. Electrical characteristics

Connector Id(s)	HSFCU_J11 HSFCU_J12
Pin number(s)	11/12*
Interface type	Output
Signal type	DC current
Current range	0 to 50 μ A
Voltage range	0 to 300 mV
Transmission mode	Balanced
Reference pin(s) (return line)	24/25*
Load impedance	6 k Ω
Corresponding command(s)	SetTCHeaterB

* Double wires interface.

4.3.3.3.2. Interface circuitry

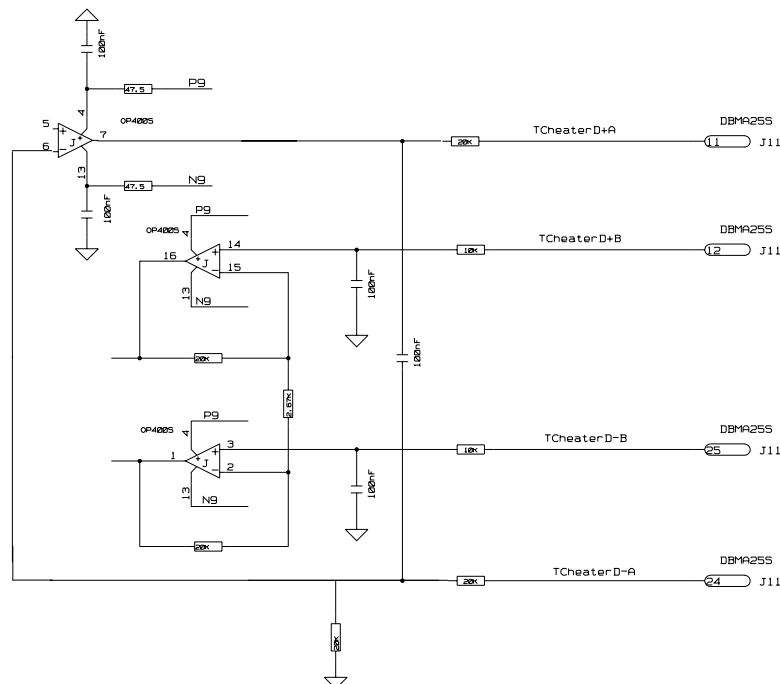

4.3.4. Calibrator

4.3.4.1. PCAL sources

4.3.4.1.1. Electrical characteristics

Connector Id(s)	HSFCU_J11 HSFCU_J12
Pin number(s)	2/3*
Interface type	Output
Signal type	DC current
Current range	0 to 7 mA
Voltage range	0 to 3.9 V
Transmission mode	Single
Reference pin(s) (return line)	7/8*
Load impedance	200 - 500 Ω
Corresponding command(s)	SetPhCalBias

* Double wires interface.

4.3.4.1.2. Interface circuitry

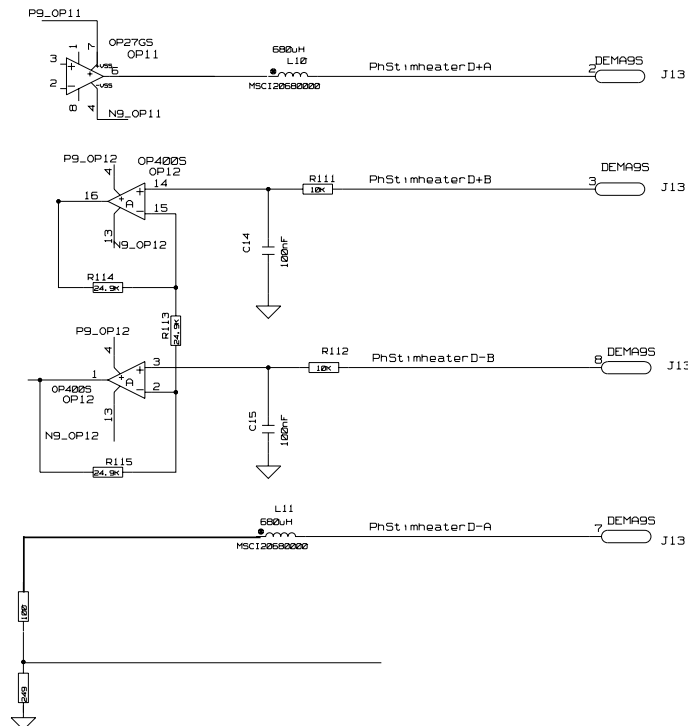

4.3.4.2. SCAL source

4.3.4.2.1. Electrical characteristics

Connector Id(s)	HSFCU_J11 HSFCU_J12
Pin number(s)	7/8, 9/10*
Interface type	Output
Signal type	DC current
Current range	0 to 5.5 mA
Voltage range	0 to 3.1 V
Transmission mode	Single
Reference pin(s) (return line)	20/21, 22/23*
Load impedance	500 Ω
Corresponding command(s)	SetSCal4Bias SetSCal2Bias

* Double wires interface.

4.3.4.2.2. Interface circuitry

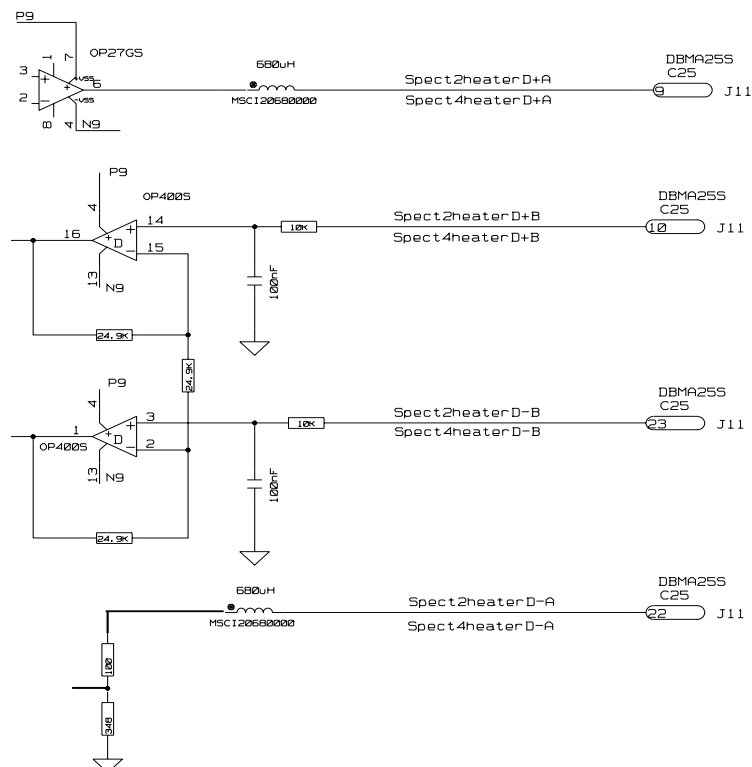

5. Connectors and Harness Definition

5.1. Overall harness configuration

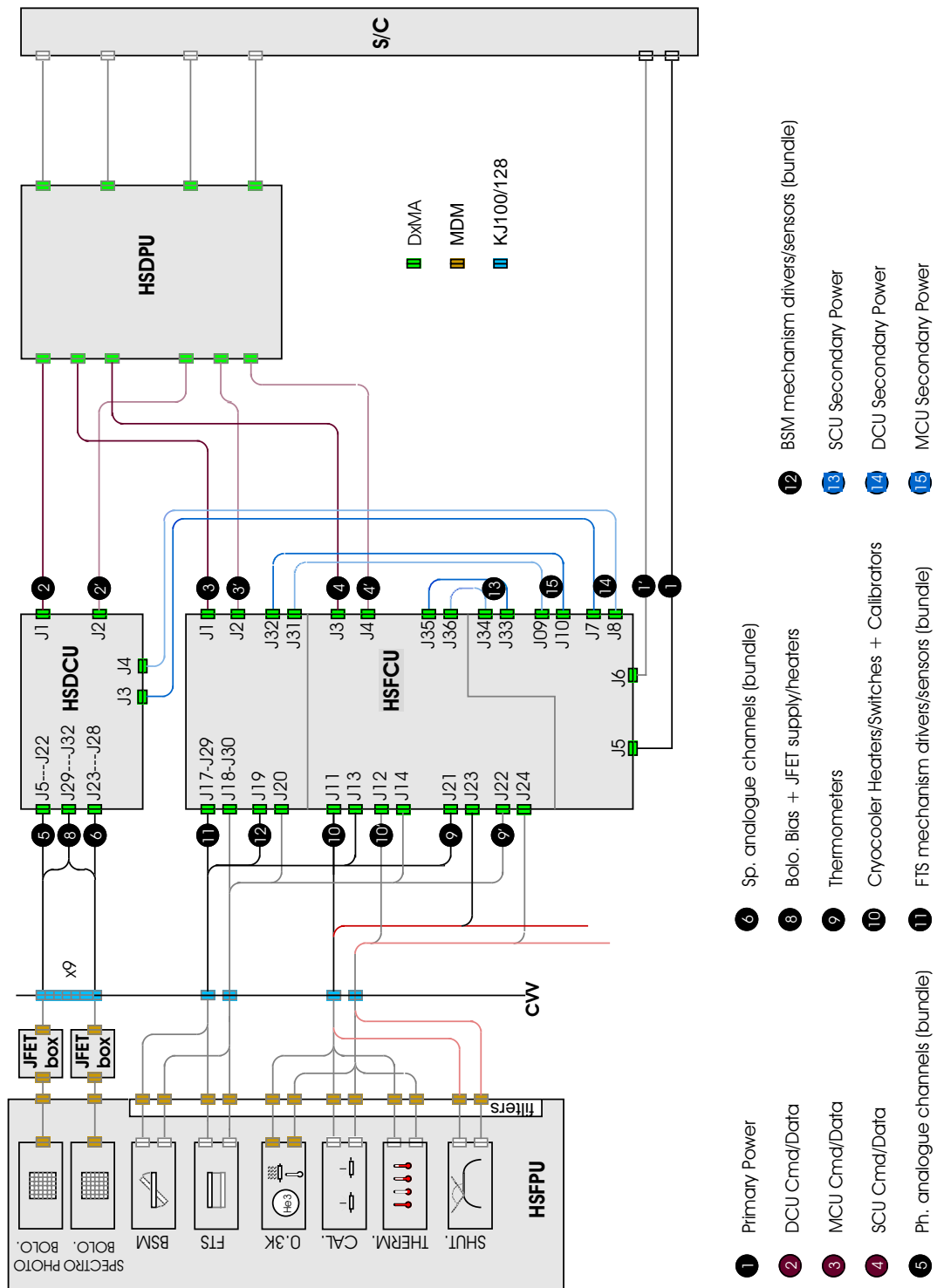

5.2. Connector layout on box

5.2.1. DCU box

5.2.1.1. Top View

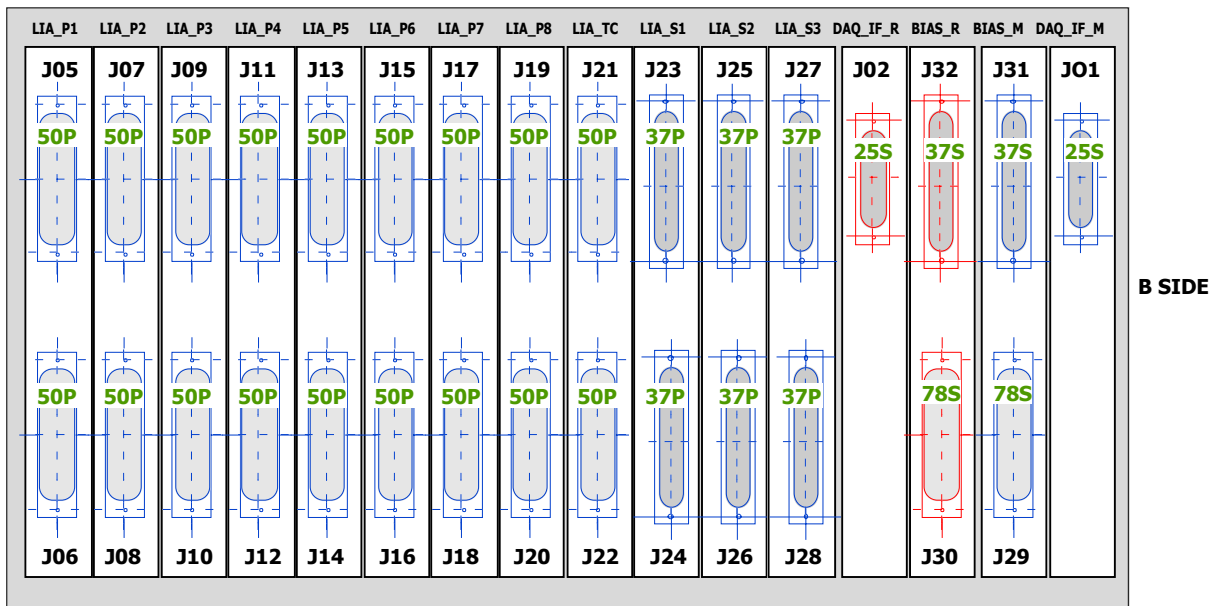

5.2.1.2. Lateral View

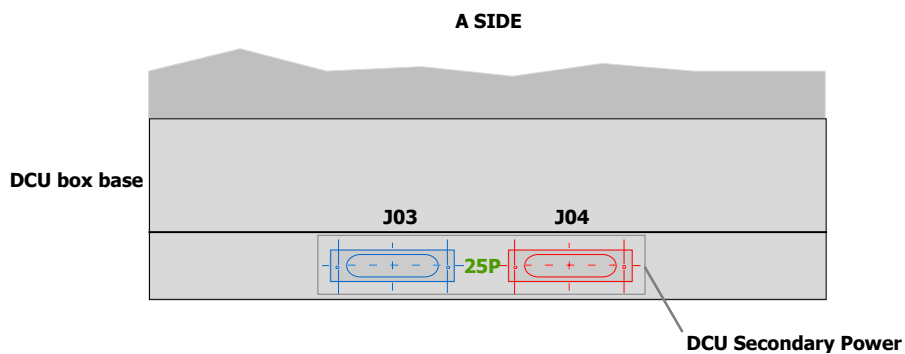

5.2.2. FCU box

5.2.2.1. Top View

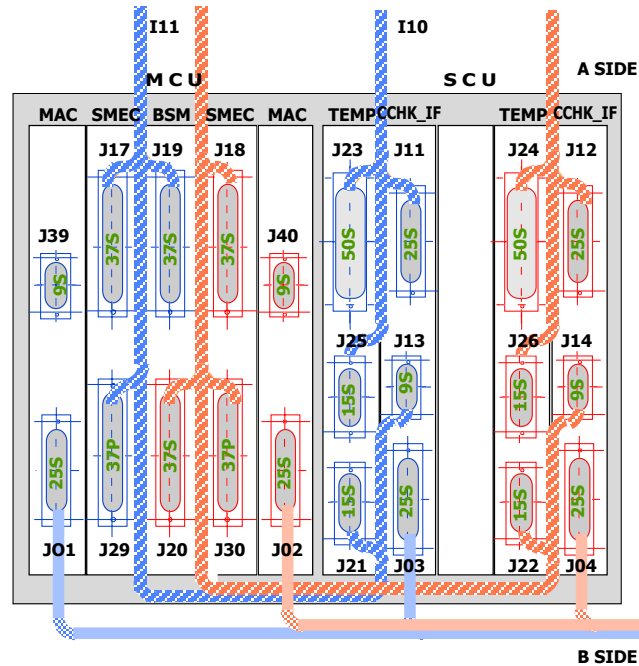

5.2.2.2. Lateral Views

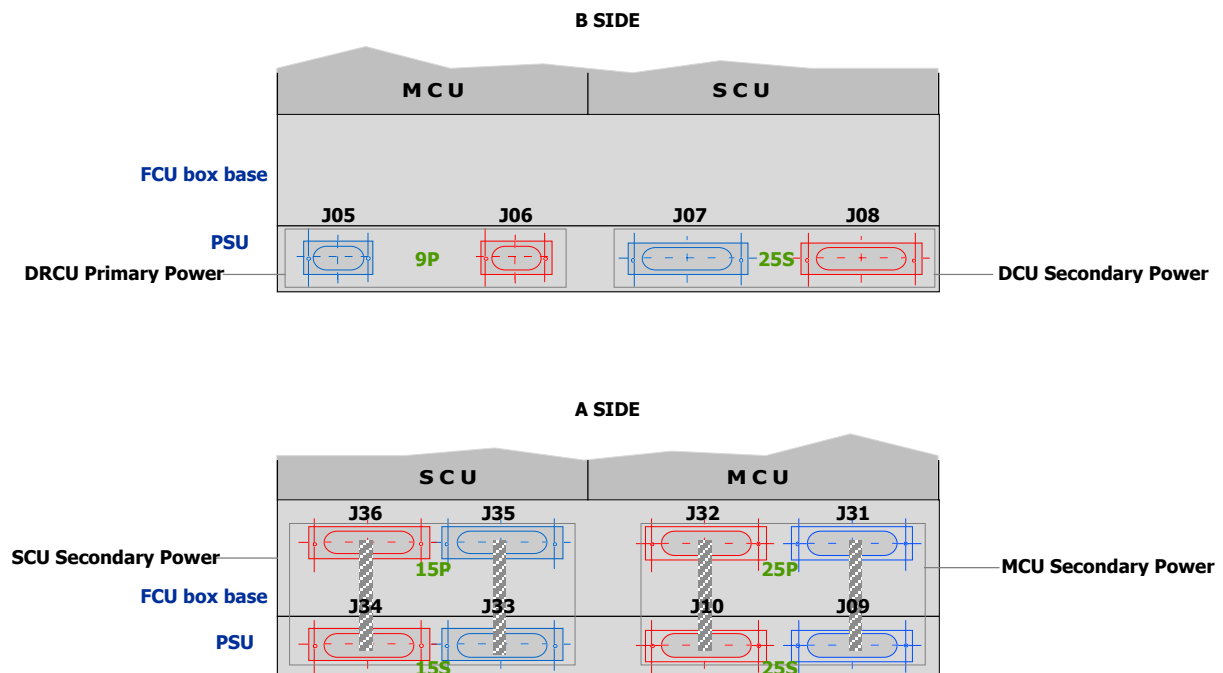

5.2.3. FCU to FPU harness tail configuration

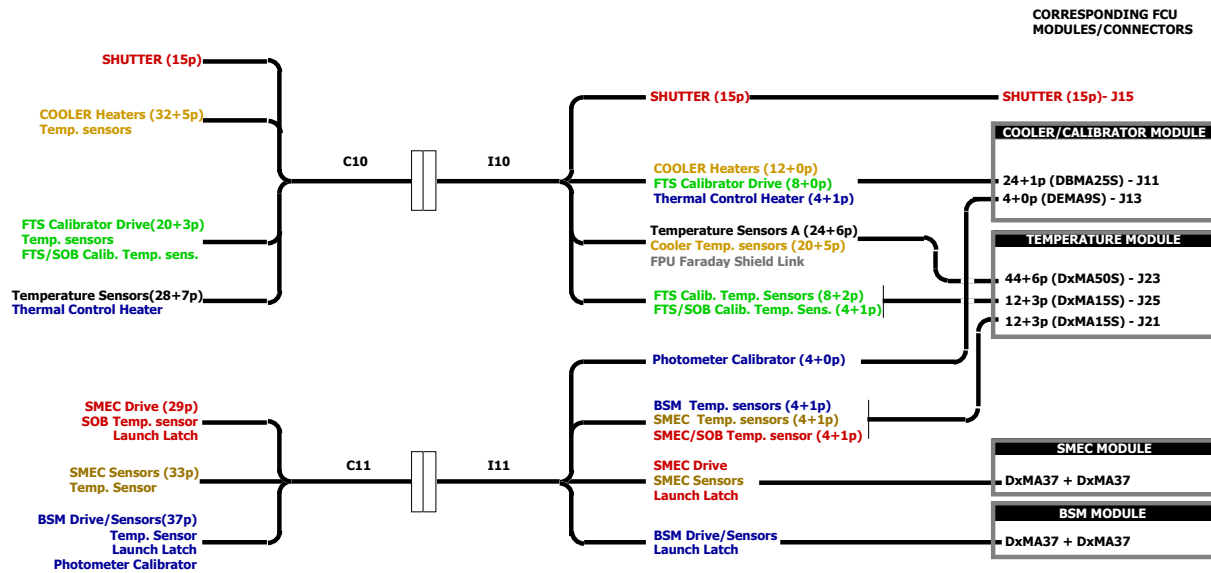

The previous figure is given for information only. A full description of the various harness is given by AD3.

5.3. Connector list

S/S	Connector Id	Connector Type	Interface Name
DCU	J01	DBMA25S	DAQ_IF_M / DPU_M
	J02	DBMA25S	DAQ_IF_R / DPU_R
	J03	DBMA25P	DCU / PSU_M
	J04	DBMA25P	DCU / PSU_R
	J05	DDMA50P	LIA_P_1 / FPU
	J06	DDMA50P	LIA_P_1 / FPU
	J07	DDMA50P	LIA_P_2 / FPU
	J08	DDMA50P	LIA_P_2 / FPU
	J09	DDMA50P	LIA_P_3 / FPU
	J10	DDMA50P	LIA_P_3 / FPU
	J11	DDMA50P	LIA_P_4 / FPU
	J12	DDMA50P	LIA_P_4 / FPU
	J13	DDMA50P	LIA_P_5 / FPU
	J14	DDMA50P	LIA_P_5 / FPU
	J15	DDMA50P	LIA_P_6 / FPU
	J16	DDMA50P	LIA_P_6 / FPU
	J17	DDMA50P	LIA_P_7 / FPU
	J18	DDMA50P	LIA_P_7 / FPU
	J19	DDMA50P	LIA_P_8 / FPU
	J20	DDMA50P	LIA_P_8 / FPU
	J21	DDMA50P	LIA_P_9 / FPU
	J22	DDMA50P	LIA_P_9 / FPU
	J23	DCMA37P	LIA_S_1 / FPU
	J24	DCMA37P	LIA_S_1 / FPU
	J25	DCMA37P	LIA_S_2 / FPU
	J26	DCMA37P	LIA_S_2 / FPU
	J27	DCMA37P	LIA_S_3 / FPU
	J28	DCMA37P	LIA_S_3 / FPU
	J29	DDMA78S	BIAS_M / FPU
	J30	DDMA78S	BIAS_R / FPU
	J31	DCMA37S	BIAS_M / FPU
	J32	DCMA37S	BIAS_R / FPU
MCU	J01	DBMA25S	MAC_M / DPU_M
MCU	J02	DBMA25S	MAC_R / DPU_R
SCU	J03	DBMA25S	CCHK_IF_M / DPU_M
SCU	J04	DBMA25S	CCHK_IF_R / DPU_R
PSU	J05	DEMA9P	PSU_M / FCDU_M
PSU	J06	DEMA9P	PSU_R / FCDU_R
PSU	J07	DBMA25S	PSU_M / DCU
PSU	J08	DBMA25S	PSU_R / DCU
FCU	J09	DBMA25S	PSU_M / MCU_M
FCU	J10	DBMA25S	PSU_R / MCU_R
SCU	J11	DBMA25S	CCHK_IF_M / FPU_COOL_CAL_M
SCU	J12	DBMA25S	CCHK_IF_R / FPU_COOL_CAL_R
SCU	J13	DEMA9S	CCHK_IF_M / FPU_PH_STIM_M
SCU	J14	DEMA9S	CCHK_IF_R / FPU_PH_STIM_R
FCU	J15	NA	NA

S/S	Connector Id	Connector Type	Interface Name
FCU	J16	NA	NA
MCU	J17	DCMA37S	SMEC_M / FPU_SMECm_1_M
MCU	J18	DCMA37S	SMEC_M / FPU_SMECm_1_R
MCU	J19	DCMA37S	BSM_M / FPU_BSM_M
MCU	J20	DCMA37S	BSM_R / FPU_BSM_R
SCU	J21	DAMA15S	TEMP_M / FPU_TS_1_M
SCU	J22	DAMA15S	TEMP_R / FPU_TS_1_R
SCU	J23	DDMA50S	TEMP_M / FPU_TS_2_M
SCU	J24	DDMA50S	TEMP_R / FPU_TS_2_R
SCU	J25	DAMA15S	TEMP_M / FPU_MEC_TS_M
SCU	J26	DAMA15S	TEMP_R / FPU_MEC_TS_R
FCU	J27	NA	NA
FCU	J28	NA	NA
MCU	J29	DCMA37P	SMEC_M / FPU_SMECm_2_M
MCU	J30	DCMA37P	SMEC_R / FPU_SMECm_2_R
MCU	J31	DBMA25P	MCU_M / PSU_M
MCU	J32	DBMA25P	MCU_R / PSU_R
PSU	J33	DAMA15S	PSU_M / SCU_M
PSU	J34	DAMA15S	PSU_R / SCU_R
SCU	J35	DAMA15P	SCU_M / PSU_M
SCU	J36	DAMA15P	SCU_R / PSU_R
MCU	J39	DEM40S	MCU_M / ITAG
MCU	J40	DEM40S	MCU_R / ITAG

Note: Hatching lines are for S/S test purpose (J39 & J40) only or FCU internal interfaces.

5.4. Connectors Description

5.4.1. Interfaces with DPU

Unit : DCU
 Sub-unit/Module : DAQ_IF
 Connector Identifier : J01
 Connector Type : DBMA25S
 Connector Name : HSDCU_J01

Pin #	Signal Name	EMC Class	Comment
1	C_CLK_SHD		Connected DPU side only
2	C_CLK_DCU_P+	2	Twisted with 15
3	C_CMD_DCU_P+	2	Twisted with 16
4	C_RES_DCU_P+	2	Twisted with 17
5	C_RES_SHD	2	Connected DCU side only
6			
7			
8	D_CLK_DCU_P+	2	Twisted with 21
9	D_CLK_SHD	2	Connected DCU side only
10	D_DAT_DCU_P+	2	Twisted with 22
11	D_GAT_DCU_P+	2	Twisted with 24
12	D_GAT_SHD	2	Connected DCU side only
13	-		
14	C_CMD_SHD	2	Connected DPU side only
15	C_CLK_DCU_P-	2	Twisted with 2
16	C_CMD_DCU_P-	2	Twisted with 3
17	C_RES_DCU_P-	2	Twisted with 4
18			
19			
20			
21	D_CLK_DCU_P-	2	Twisted with 15
22	D_DAT_DCU_P-	2	Twisted with 10
23	D_DAT_SHD	2	Connected DCU side only
24	D_GAT_DCU_P-	2	Twisted with 11
25	-		

Unit : FCU
Sub-unit/Module : MCU/MAC
Connector Identifier : J01
Connector Type : DBMA25S
Connector Name : HSFCU_J01

Pin #	Signal Name	EMC Class	Signal Description
1	C_CLK_SHD		Connected DPU side only
2	C_CLK_MCU_P+	2	Twisted with 15
3	C_CMD_MCU_P+	2	Twisted with 16
4	C_RES_MCU_P+	2	Twisted with 17
5	C_RES_SHD	2	Connected MCU side only
6			
7			
8	D_CLK_MCU_P+	2	Twisted with 21
9	D_CLK_SHD	2	Connected MCU side only
10	D_DAT_MCU_P+	2	Twisted with 22
11	D_GAT_MCU_P+	2	Twisted with 24
12	D_GAT_SHD	2	Connected MCU side only
13	-		
14	C_CMD_SHD	2	Connected DPU side only
15	C_CLK_MCU_P-	2	Twisted with 2
16	C_CMD_MCU_P-	2	Twisted with 3
17	C_RES_MCU_P-	2	Twisted with 4
18			
19			
20			
21	D_CLK_MCU_P-	2	Twisted with 15
22	D_DAT_MCU_P-	2	Twisted with 10
23	D_DAT_SHD	2	Connected MCU side only
24	D_GAT_MCU_P-	2	Twisted with 11
25	-		

Unit : FCU
Sub-unit/Module : SCU/CCHK_IF
Connector Identifier : J03
Connector Type : DBMA25S
Connector Name : HSFCU_J03

Pin #	Signal Name	EMC Class	Signal Description
1	C_CLK_SHD		Connected DPU side only
2	C_CLK_SCU_P+	2	Twisted with 15
3	C_CMD_SCU_P+	2	Twisted with 16
4	C_RES_SCU_P+	2	Twisted with 17
5	C_RES_SHD	2	Connected SCU side only
6			
7			
8	D_CLK_SCU_P+	2	Twisted with 21
9	D_CLK_SHD	2	Connected SCU side only
10	D_DAT_SCU_P+	2	Twisted with 22
11	D_GAT_SCU_P+	2	Twisted with 24
12	D_GAT_SHD	2	Connected SCU side only
13	-		
14	C_CMD_SHD	2	Connected DPU side only
15	C_CLK_SCU_P-	2	Twisted with 2
16	C_CMD_SCU_P-	2	Twisted with 3
17	C_RES_SCU_P-	2	Twisted with 4
18			
19			
20			
21	D_CLK_SCU_P-	2	Twisted with 15
22	D_DAT_SCU_P-	2	Twisted with 10
23	D_DAT_SHD	2	Connected SCU side only
24	D_GAT_SCU_P-	2	Twisted with 11
25	-		

Unit : DCU
Sub-unit/Module : DAQ_IF
Connector Identifier : J02
Connector Type : DBMA25S
Connector Name : HSDCU_J02

Pin #	Signal Name	EMC		Signal Description
			Class	
1	C_CLK_SHD			Connected DPU side only
2	C_CLK_DCU_R+	2		Twisted with 15
3	C_CMD_DCU_R+	2		Twisted with 16
4	C_RES_DCU_R+	2		Twisted with 17
5	C_RES_SHD	2		Connected DCU side only
6				
7				
8	D_CLK_DCU_R+	2		Twisted with 21
9	D_CLK_SHD	2		Connected DCU side only
10	D_DAT_DCU_R+	2		Twisted with 22
11	D_GAT_DCU_R+	2		Twisted with 24
12	D_GAT_SHD	2		Connected DCU side only
13	-			
14	C_CMD_SHD	2		Connected DPU side only
15	C_CLK_DCU_R-	2		Twisted with 2
16	C_CMD_DCU_R-	2		Twisted with 3
17	C_RES_DCU_R-	2		Twisted with 4
18				
19				
20				
21	D_CLK_DCU_R-	2		Twisted with 15
22	D_DAT_DCU_R-	2		Twisted with 10
23	D_DAT_SHD	2		Connected DCU side only
24	D_GAT_DCU_R-	2		Twisted with 11
25	-			

Unit : FCU
 Sub-unit/Module : MCU/MAC
 Connector Identifier : J02
 Connector Type : DBMA25S
 Connector Name : HSFCU_J02

Pin #	Signal Name	EMC Class	Signal Description
1	C_CLK_SHD		Connected DPU side only
2	C_CLK_MCU_R+	2	Twisted with 15
3	C_CMD_MCU_R+	2	Twisted with 16
4	C_RES_MCU_R+	2	Twisted with 17
5	C_RES_SHD	2	Connected MCU side only
6			
7			
8	D_CLK_MCU_R+	2	Twisted with 21
9	D_CLK_SHD	2	Connected MCU side only
10	D_DAT_MCU_R+	2	Twisted with 22
11	D_GAT_MCU_R+	2	Twisted with 24
12	D_GAT_SHD	2	Connected MCU side only
13	-		
14	C_CMD_SHD	2	Connected DPU side only
15	C_CLK_MCU_R-	2	Twisted with 2
16	C_CMD_MCU_R-	2	Twisted with 3
17	C_RES_MCU_R-	2	Twisted with 4
18			
19			
20			
21	D_CLK_MCU_R-	2	Twisted with 15
22	D_DAT_MCU_R-	2	Twisted with 10
23	D_DAT_SHD	2	Connected MCU side only
24	D_GAT_MCU_R-	2	Twisted with 11
25	-		

Unit : FCU
 Sub-unit/Module : SCU/CCHK_IF
 Connector Identifier : J04
 Connector Type : DBMA25S
 Connector Name : HSFCU_J04

Pin #	Signal Name	EMC Class	Signal Description
1	C_CLK_SHD		Connected DPU side only
2	C_CLK_SCU_R+	2	Twisted with 15
3	C_CMD_SCU_R+	2	Twisted with 16
4	C_RES_SCU_R+	2	Twisted with 17
5	C_RES_SHD	2	Connected SCU side only
6			
7			
8	D_CLK_SCU_R+	2	Twisted with 21
9	D_CLK_SHD	2	Connected SCU side only
10	D_DAT_SCU_R+	2	Twisted with 22
11	D_GAT_SCU_R+	2	Twisted with 24
12	D_GAT_SHD	2	Connected SCU side only
13	-		
14	C_CMD_SHD	2	Connected DPU side only
15	C_CLK_SCU_R-	2	Twisted with 2
16	C_CMD_SCU_R-	2	Twisted with 3
17	C_RES_SCU_R-	2	Twisted with 4
18			
19			
20			
21	D_CLK_SCU_R-	2	Twisted with 15
22	D_DAT_SCU_R-	2	Twisted with 10
23	D_DAT_SHD	2	Connected SCU side only
24	D_GAT_SCU_R-	2	Twisted with 11
25	-		

5.4.2. Interfaces with S/C

Unit : FCU
 Sub-unit : PSU
 Connector Identifier : J05
 Connector Type : DEMA9P
 Connector Name : HSFCU_J05

Pin #	Signal Name	EMC Class	Signal Description
1			
2	PWR_28V_P	1	
3			
4	RTN_PWR_P	1	
5			
6			
7	PWR_28V_P	1	
8	RTN_PWR_P	1	
9			

Unit : FCU
 Sub-unit : PSU
 Connector Identifier : J06
 Connector Type : DEMA9P
 Connector Name : HSFCU_J06

Pin #	Signal Name	EMC Class	Signal Description
1			
2	PWR_28V_R	1	
3			
4	RTN_PWR_R	1	
5			
6			
7	PWR_28V_R	1	
8	RTN_PWR_R	1	
9			

5.4.3. Interfaces with FPU

5.4.3.1. DCU Interfaces

5.4.3.1.1. LIA_P Module

Unit : DCU
 Sub-unit/Module : LIA_P
 Connector Identifier : J05, J07, J09, J11, J13, J15, J17, J19
 Connector Type : DDMA50P
 Connector Name : HSDCU_J05 to HSDCU_J19

Pin #	Signal Name	EMC Class	Signal Description
1	Channel 1 +	3	
18	Channel 1 -	3	
34	Channel 1 shld	3	Connected individually to connector body
2	Channel 2 +	3	
19	Channel 2 -	3	
35	Channel 2 shld	3	Connected individually to connector body
3	Channel 3 +	3	
20	Channel 3 -	3	
36	Channel 3 shld	3	Connected individually to connector body
4	Channel 4 +	3	
21	Channel 4 -	3	
37	Channel 4 shld	3	Connected individually to connector body
5	Channel 5 +	3	
22	Channel 5 -	3	
38	Channel 5 shld	3	Connected individually to connector body
6	Channel 6 +	3	
23	Channel 6 -	3	
39	Channel 6 shld	3	Connected individually to connector body
7	Channel 7 +	3	
24	Channel 7 -	3	
40	Channel 7 shld	3	Connected individually to connector body
8	Channel 8 +	3	
25	Channel 8 -	3	
41	Channel 8 shld	3	Connected individually to connector body
9	GND WIRE	3	
42	FPU Faraday Shield Link	3	
26	Channel 9 +	3	
10	Channel 9 -	3	
43	Channel 9 shld	3	Connected individually to connector body
27	Channel 10 +	3	
11	Channel 10 -	3	
44	Channel 10 shld	3	Connected individually to connector body
28	Channel 11 +	3	
12	Channel 11 -	3	

45	Channel 11 shld	3	Connected individually to connector body
29	Channel 12 +	3	
13	Channel 12 -	3	
46	Channel 12 shld	3	Connected individually to connector body
30	Channel 13 +	3	
14	Channel 13 -	3	
47	Channel 13 shld	3	Connected individually to connector body
31	Channel 14 +	3	
15	Channel 14 -	3	
48	Channel 14 shld	3	Connected individually to connector body
32	Channel 15 +	3	
16	Channel 15 -	3	
49	Channel 15 shld	3	Connected individually to connector body
33	Channel 16 +	3	
17	Channel 16 -	3	
50	Channel 16 shld	3	Connected individually to connector body

Unit : DCU
 Sub-unit/Module : LIA_P
 Connector Identifier : J06, J08, J10, J12, J14, J16, J18, J20
 Connector Type : DDMA50P
 Connector Name : HSDCU_J06 to HSDCU_J20

Pin #	Signal Name	EMC Class	Signal Description
1	Channel 17 +	3	
18	Channel 17 -	3	
34	Channel 17 shld	3	Connected individually to connector body
2	Channel 18 +	3	
19	Channel 18 -	3	
35	Channel 18 shld	3	Connected individually to connector body
3	Channel 19 +	3	
20	Channel 19 -	3	
36	Channel 19 shld	3	Connected individually to connector body
4	Channel 20 +	3	
21	Channel 20 -	3	
37	Channel 20 shld	3	Connected individually to connector body
5	Channel 21 +	3	
22	Channel 21 -	3	
38	Channel 21 shld	3	Connected individually to connector body
6	Channel 22 +	3	
23	Channel 22 -	3	
39	Channel 22 shld	3	Connected individually to connector body
7	Channel 23 +	3	
24	Channel 23 -	3	
40	Channel 23 shld	3	Connected individually to connector body
8	Channel 24 +	3	
25	Channel 24 -	3	
41	Channel 24 shld	3	Connected individually to connector body
9	GND WIRE	3	
42	FPU Faraday Shield Link	3	
26	Channel 25 +	3	
10	Channel 25 -	3	
43	Channel 25 shld	3	Connected individually to connector body
27	Channel 26 +	3	
11	Channel 26 -	3	
44	Channel 26 shld	3	Connected individually to connector body
28	Channel 27 +	3	
12	Channel 27 -	3	
45	Channel 27 shld	3	Connected individually to connector body
29	Channel 28 +	3	
13	Channel 28 -	3	
46	Channel 28 shld	3	Connected individually to connector body
30	Channel 29 +	3	
14	Channel 29 -	3	
47	Channel 29 shld	3	Connected individually to connector body
31	Channel 30 +	3	

15	Channel 30 -	3	
48	Channel 30 shld	3	Connected individually to connector body
32	Channel 31 +	3	
16	Channel 31 -	3	
49	Channel 31 shld	3	Connected individually to connector body
33	Channel 32 +	3	
17	Channel 32 -	3	
50	Channel 32 shld	3	Connected individually to connector body

5.4.3.1.2. LIA_TC Module

Unit : DCU
 Sub-unit/Module : LIA_TC
 Connector Identifier : J21
 Connector Type : DDMA50P
 Connector Name : HSDCU_J21

Pin #	Signal Name	EMC Class	Signal Description
1	Channel 1 +	3	
18	Channel 1 -	3	
34	Channel 1 shld	3	Connected individually to connector body
2	Channel 2 +	3	
19	Channel 2 -	3	
35	Channel 2 shld	3	Connected individually to connector body
3	Channel 3 +	3	
20	Channel 3 -	3	
36	Channel 3shld	3	Connected individually to connector body
4	Channel 4 +	3	
21	Channel 4 -	3	
37	Channel 4 shld	3	Connected individually to connector body
5	Channel 5 +	3	
22	Channel 5 -	3	
38	Channel 5 shld	3	Connected individually to connector body
6	Channel 6 +	3	
23	Channel 6 -	3	
39	Channel 6 shld	3	Connected individually to connector body
7	Channel 7 +	3	
24	Channel 7 -	3	
40	Channel 7 shld	3	Connected individually to connector body
8	Channel 8 +	3	
25	Channel 8 -	3	
41	Channel 8 shld	3	Connected individually to connector body
9	GND WIRE	3	NC DCU side
42	FPU Faraday Shield Link	3	
26	Channel 9 +	3	
10	Channel 9 -	3	
43	Channel 9 shld	3	Connected individually to connector body
27	Channel 10 +	3	
11	Channel 10 -	3	
44	Channel 10 shld	3	Connected individually to connector body
28	Channel 11 +	3	
12	Channel 11 -	3	
45	Channel 11 shld	3	Connected individually to connector body
29	Channel 12 +	3	
13	Channel 12 -	3	

46	Channel 12 shld	3	Connected individually to connector body
30	Channel 13 +	3	
14	Channel 13 -	3	
47	Channel 13 shld	3	Connected individually to connector body
31	Channel 14 +	3	
15	Channel 14 -	3	
48	Channel 14 shld	3	Connected individually to connector body
32	Channel 15 +	3	
16	Channel 15 -	3	
49	Channel 15 shld	3	Connected individually to connector body
33	Channel 16 +	3	
17	Channel 16 -	3	
50	Channel 16 shld	3	Connected individually to connector body

Unit : DCU
Sub-unit/Module : LIA_TC
Connector Identifier : J22
Connector Type : DDMA50P
Connector Name : HSDCU_J22

Pin #	Signal Name	EMC Class	Signal Description
1	Channel 17 +	3	
18	Channel 17 -	3	
34	Channel 17 shld	3	Connected individually to connector body
2	Channel 18 +	3	
19	Channel 18 -	3	
35	Channel 18 shld	3	Connected individually to connector body
3	Channel 19 +	3	
20	Channel 19 -	3	
36	Channel 19 shld	3	Connected individually to connector body
4	Channel 20 +	3	
21	Channel 20 -	3	
37	Channel 20 shld	3	Connected individually to connector body
5	Channel 21 +	3	
22	Channel 21 -	3	
38	Channel 21 shld	3	Connected individually to connector body
6	Channel 22 +	3	
23	Channel 22 -	3	
39	Channel 22 shld	3	Connected individually to connector body
7	Channel 23 +	3	
24	Channel 23 -	3	
40	Channel 23 shld	3	Connected individually to connector body
8	Channel 24 +	3	
25	Channel 24 -	3	
41	Channel 24 shld	3	Connected individually to connector body
9	GND WIRE	3	NC DCU side
42	FPU Faraday Shield Link	3	
26	Channel 25 +	3	
10	Channel 25 -	3	
43	Channel 25 shld	3	Connected individually to connector body
27	Channel 26 +	3	
11	Channel 26 -	3	
44	Channel 26 shld	3	Connected individually to connector body
28	Channel 27 +	3	
12	Channel 27 -	3	
45	Channel 27 shld	3	Connected individually to connector body
29	Channel 28 +	3	
13	Channel 28 -	3	
46	Channel 28 shld	3	Connected individually to connector body
30	Channel 29 +	3	
14	Channel 29 -	3	
47	Channel 29 shld	3	Connected individually to connector body
31	TC Channel 1 +	3	

15	TC Channel 1 -	3	
48	TC Channel 1 shld	3	Connected individually to connector body
32	TC Channel 2 +	3	
16	TC Channel 2 -	3	
49	TC Channel 2 shld	3	Connected individually to connector body
33	TC Channel 3 +	3	
17	TC Channel 3 -	3	
50	TC Channel 3 shld	3	Connected individually to connector body

5.4.3.1.3. LIA_S Module

Unit : DCU
 Sub-unit/Module : LIA_S
 Connector Identifier : J23, J25
 Connector Type : DCMA37P
 Connector Name : HSDCU_J23, HSDCU_J25

Pin #	Signal Name	EMC Class	Signal Description
1	Channel 1 shld	3	Connected individually to connector body
2	Channel 1 -	3	
3	Channel 2 +	3	
4	Channel 3 shld	3	Connected individually to connector body
5	Channel 3 -	3	
6	Channel 4 +	3	
7	Channel 5 shld	3	Connected individually to connector body
8	Channel 5 -	3	
9	Channel 6 +	3	
10	FPU Faraday Shield link	3	
11	Channel 7 +	3	
12	Channel 8 -	3	
13	Channel 8 shld	3	Connected individually to connector body
14	Channel 9 +	3	
15	Channel 10 -	3	
16	Channel 10 shld	3	Connected individually to connector body
17	Channel 11 +	3	
18	Channel 12 -	3	
19	Channel 12 shld	3	Connected individually to connector body
20	Channel 1 +	3	
21	Channel 2 shld	3	Connected individually to connector body
22	Channel 2 -	3	
23	Channel 3 +	3	
24	Channel 4 shld	3	Connected individually to connector body
25	Channel 4 -	3	
26	Channel 5 +	3	
27	Channel 6 shld	3	Connected individually to connector body
28	Channel 6 -	3	
29	Channel 7 -	3	
30	Channel 7 shld	3	Connected individually to connector body
31	Channel 8 +	3	
32	Channel 9 -	3	
33	Channel 9 shld	3	Connected individually to connector body
34	Channel 10 +	3	
35	Channel 11 -	3	
36	Channel 11 shld	3	Connected individually to connector body
37	Channel 12 +	3	

Unit : DCU
Sub-unit/Module : LIA_S
Connector Identifier : J27
Connector Type : DCMA37P
Connector Name : HSDCU_J27

Pin #	Signal Name	EMC Class	Signal Description
1	Channel 1 shld	3	Connected individually to connector body
2	Channel 1 -	3	
3	Channel 2 +	3	
4	Channel 3 shld	3	Connected individually to connector body
5	Channel 3 -	3	
6	Channel 4 +	3	
7	Channel 5 shld	3	Connected individually to connector body
8	Channel 5 -	3	
9	Channel 6 +	3	
10	SLW ground wire	3	
11	Channel 7 +	3	
12	Channel 8 -	3	
13	Channel 8 shld	3	Connected individually to connector body
14	Channel 9 +	3	
15	Channel 10 -	3	
16	Channel 10 shld	3	Connected individually to connector body
17	Channel 11 +	3	
18	Channel 12 -	3	
19	Channel 12 shld	3	Connected individually to connector body
20	Channel 1 +	3	
21	Channel 2 shld	3	Connected individually to connector body
22	Channel 2 -	3	
23	Channel 3 +	3	
24	Channel 4 shld	3	Connected individually to connector body
25	Channel 4 -	3	
26	Channel 5 +	3	
27	Channel 6 shld	3	Connected individually to connector body
28	Channel 6 -	3	
29	Channel 7 -	3	
30	Channel 7 shld	3	Connected individually to connector body
31	Channel 8 +	3	
32	Channel 9 -	3	
33	Channel 9 shld	3	Connected individually to connector body
34	Channel 10 +	3	
35	Channel 11 -	3	
36	Channel 11 shld	3	Connected individually to connector body
37	Channel 12 +	3	

Unit : DCU
 Sub-unit/Module : LIA_S
 Connector Identifier : J24, J26
 Connector Type : DCMA37P
 Connector Name : HSDCU_J24, HSDCU_J26

Pin#	Signal Name	EMC Class	Signal Description
1	Channel 13 shld	3	Connected individually to connector body
2	Channel 13 -	3	
3	Channel 14 +	3	
4	Channel 15 shld	3	Connected individually to connector body
5	Channel 15 -	3	
6	Channel 16 +	3	
7	Channel 17 shld	3	Connected individually to connector body
8	Channel 17 -	3	
9	Channel 18 +	3	
10	SSW ground wire	3	NC DCU side
11	Channel 19 +	3	
12	Channel 20 -	3	
13	Channel 20 shld	3	Connected individually to connector body
14	Channel 21 +	3	
15	Channel 22 -	3	
16	Channel 22 shld	3	Connected individually to connector body
17	Channel 23 +	3	
18	Channel 24 -	3	
19	Channel 24 shld	3	Connected individually to connector body
20	Channel 13 +	3	
21	Channel 14 shld	3	Connected individually to connector body
22	Channel 14 -	3	
23	Channel 15 +	3	
24	Channel 16 shld	3	Connected individually to connector body
25	Channel 16 -	3	
26	Channel 17 +	3	
27	Channel 18 shld	3	Connected individually to connector body
28	Channel 18 -	3	
29	Channel 19 -	3	
30	Channel 19 shld	3	Connected individually to connector body
31	Channel 20 +	3	
32	Channel 21 -	3	
33	Channel 21 shld	3	Connected individually to connector body
34	Channel 22 +	3	
35	Channel 23 -	3	
36	Channel 23 shld	3	Connected individually to connector body
37	Channel 24 +	3	

Unit : DCU
 Sub-unit/Module : LIA_S
 Connector Identifier : J28
 Connector Type : DCMA37P
 Connector Name : HSDCU_J28

Pin#	Signal Name	EMC Class	Signal Description
1	Channel 13 shld	3	Connected individually to connector body
2	Channel 13 -	3	
3	Channel 14 +	3	
4	Channel 15 shld	3	Connected individually to connector body
5	Channel 15 -	3	
6	Channel 16 +	3	
7	Channel 17 shld	3	Connected individually to connector body
8	Channel 17 -	3	
9	Channel 18 +	3	
10	SLW ground wire	3	NC DCU side
11	Channel 19 +	3	
12	Channel 20 -	3	
13	Channel 20 shld	3	Connected individually to connector body
14	Channel 21 +	3	
15	Channel 22 -	3	
16	Channel 22 shld	3	Connected individually to connector body
17	Channel 23 +	3	
18	Channel 24 -	3	
19	Channel 24 shld	3	Connected individually to connector body
20	Channel 13 +	3	
21	Channel 14 shld	3	Connected individually to connector body
22	Channel 14 -	3	
23	Channel 15 +	3	
24	Channel 16 shld	3	Connected individually to connector body
25	Channel 16 -	3	
26	Channel 17 +	3	
27	Channel 18 shld	3	Connected individually to connector body
28	Channel 18 -	3	
29	Channel 19 -	3	
30	Channel 19 shld	3	Connected individually to connector body
31	Channel 20 +	3	
32	Channel 21 -	3	
33	Channel 21 shld	3	Connected individually to connector body
34	Channel 22 +	3	
35	Channel 23 -	3	
36	Channel 23 shld	3	Connected individually to connector body
37	Channel 24 +	3	

5.4.3.1.4. *BIAS Module*

Unit : DCU
 Sub-unit/Module : BIAS_P (Main)
 Connector Identifier : J29
 Connector Type : DDMA78S
 Connector Name : HSDCU_J29

Pin#	Signal Name	EMC Class	Signal Description
1	Vdd1_P	3	Assigned to P250_JFET1 of PhSWJfetBias command
2	Vss1_P	3	Assigned to VSS1 of PhSWJfetVSS command
3	Vdd2_P	3	Assigned to P250_JFET2 of PhSWJfetBias command
4	Vdd3_P	3	Assigned to P250_JFET3 of PhSWJfetBias command
5	Vss3_P	3	Assigned to VSS3 of PhSWJfetVSS command
6	PBias_P250	3	Assigned to P250 of PhotoBiasAmpl command
7	FPU_Faraday_shield		Connected to connector body
8	Pheater_PSW1	3	Connected internally to Gnd_Bias_Ph
9	Nheater_PSW1	3	Assigned to PhotoHeaterVolt of PhotoHeater command
10	Vdd7_P	3	Assigned to P350_JFET1 of PhMLWJfetBias command
11	Vss7_P	3	Assigned to VSS1 of PhMWJfetVSS command
12	Vdd8_P	3	Assigned to P350_JFET2 of PhMLWJfetBias command
13	NBias_P350	3	Assigned to P350 of PhotoBiasAmpl command
14	Pbias_P350	3	Assigned to P350 of PhotoBiasAmpl command
15	Nheater_PMW1	3	Assigned to PhotoHeaterVolt of PhotoHeater command
16	Pheater_PMW1	3	Connected internally to Gnd_Bias_Ph
17	Vss11_P	3	Assigned to VSS1 of PhLWJfetVSS command
18	Vdd12_P	3	Assigned to P500_JFET2 of PhMLWJfetBias command
19	Vss12_P	3	Assigned to VSS2 of PhLWJfetVSS command
20	Pheater_PLW1		Connected internally to Gnd_Bias_Ph
21	Vdd1_Vss1_P_SHD		Connected internally to Gnd_Bias_Ph
22	Vdd2_Vss2_P_SHD		Connected internally to Gnd_Bias_Ph
23	Vss2_P	3	Assigned to VSS2 of PhSWJfetVSS command
24	Vdd3_Vss3_P_SHD		Connected internally to Gnd_Bias_Ph
25	Bias_P250_SHD		Connected internally to Gnd_Bias_Ph
26	Nbias_250	3	Assigned to P250 of PhotoBiasAmpl command
27	PSW_Gnd		Connected internally to Gnd_Bias_Ph
28	Heater_PSW1_SHD		Connected internally to Gnd_Bias_Ph
29	PheaterPSW2	3	Connected internally to Gnd_Bias_Ph
30	Vdd7_Vss7_P_SHD		Connected internally to Gnd_Bias_Ph
31	Vss8_P	3	Assigned to VSS2 of PhMWJfetVSS command
32	Vdd8_Vss8_P_SHD		Connected internally to Gnd_Bias_Ph
33	Bias_P350_SHD		Connected internally to Gnd_Bias_Ph
34	PMW_Gnd		
35	Heater_PMW1_SHD		Connected internally to Gnd_Bias_Ph
36	Vdd11_P	3	Assigned to P500_JFET1 of PhMLWJfetBias command
37	Vdd11_Vss11_P_SHD		Connected internally to Gnd_Bias_Ph
38	Vdd12_Vss12_P_SHD		Connected internally to Gnd_Bias_Ph

39	Nheater_PLW1	3	Assigned to PhotoHeaterVolt of PhotoHeater command
40	Vdd4_Vss4_P_SHD		Connected internally to Gnd_Bias_Ph
41	Vdd4_P	3	Assigned to P250_JFET4 of PhSWJfetBias command
42	Vdd5_Vss5_P_SHD		Connected internally to Gnd_Bias_Ph
43	Vdd6_Vss6_P_SHD		Connected internally to Gnd_Bias_Ph
44	Vss6_P	3	Assigned to VSS6 of PhSWJfetVSS command
45	Bias_P250_SHD		Connected internally to Gnd_Bias_Ph
46	Bias_P250_SHD		Connected internally to Gnd_Bias_Ph
47	Pbias_P250	3	Assigned to P250 of PhotoBiasAmpl command
48	Heater_PSW2_3_SHD		Connected internally to Gnd_Bias_Ph
49	Nheater_PSW2	3	Assigned to PhotoHeaterVolt of PhotoHeater command
50	Vdd9_Vss9_P_SHD		Connected internally to Gnd_Bias_Ph
51	Vdd10_Vss10_P_SHD		Connected internally to Gnd_Bias_Ph
52	Vss10_P	3	Assigned to VSS4 of PhMWJfetVSS command
53	Bias_P350_SHD		Connected internally to Gnd_Bias_Ph
54	Pheater_PMW2	3	Connected internally to Gnd_Bias_Ph
55	Heater_PMW2_SHD		Connected internally to Gnd_Bias_Ph
56	Bias_P500_SHD		Connected internally to Gnd_Bias_Ph
57	Nbias_P500	3	Assigned to P500 of PhotoBiasAmpl command
58	Bias_P500_SHD		Connected internally to Gnd_Bias_Ph
59	Heater_PLW1_SHD		Connected internally to Gnd_Bias_Ph
60	Vss4_P	3	Assigned to VSS4 of PhSWJfetVSS command
61	Vdd5_P	3	Assigned to P250_JFET5 of PhSWJfetBias command
62	Vss5_P	3	Assigned to VSS5 of PhSWJfetVSS command
63	Vdd6_P	3	Assigned to P250_JFET6 of PhSWJfetBias command
64	Nbias_P250	3	Assigned to P250 of PhotoBiasAmpl command
65	Pbias_P250	3	Assigned to P250 of PhotoBiasAmpl command
66	Nbias_P250	3	Assigned to P250 of PhotoBiasAmpl command
67	Nheater_PSW3	3	Assigned to PhotoHeaterVolt of PhotoHeater command
68	Pheater_PSW3	3	Connected internally to Gnd_Bias_Ph
69	Vdd9_P	3	Assigned to P350_JFET3 of PhMLWJfetBias command
70	Vss9_P	3	Assigned to VSS3 of PhMWJfetVSS command
71	Vdd10_P	3	Assigned to P350_JFET4 of PhMLWJfetBias command
72	Nbias_P350	3	Assigned to P350 of PhotoBiasAmpl command
73	Pbias_P350	3	Assigned to P350 of PhotoBiasAmpl command
74	Nheater_PMW2	3	Assigned to PhotoHeaterVolt of PhotoHeater command
75	Pbias_P500	3	Assigned to P500 of PhotoBiasAmpl command
76	Nbias_P500	3	Assigned to P500 of PhotoBiasAmpl command
77	Pbias_P500	3	Assigned to P500 of PhotoBiasAmpl command
78	PLW_gnd		

Note: all xx_SHD are onnected to connector body

Unit : DCU
Sub-unit/Module : BIAS_S (Main)
Connector Identifier : J31
Connector Type : DCMA37S
Connector Name : HSDCU_J31

Pin#	Signal Name	EMC Class	Signal Description
1	PBias_TC	3	Assigned to TC of PhotoBiasAmpl command
2	Bias_TC_SHD		Connected internally to Gnd_Bias_Ph
3	Vss_TC	3	Assigned to TC of PhSWJfetVss
4	Nbias_SLW	3	Assigned to LW of SpectroBiasAmpl command
5	Pbias_SLW	3	Assigned to LW of SpectroBiasAmpl command
6	SLW_Gnd_SHDs		Connected internally to Gnd_Bias_Sp
7	Vss1_S	3	Assigned to VSS of SpLWJfetVSS command
8	Vdd1_S	3	Assigned to SLW_JFET1 of SpSLWJfetPWR command
9	Bias_SSW_SHD		Connected internally to Gnd_Bias_Sp
10	NBias_SSW	3	Assigned to SW of SpectroBiasAmpl command
11	Vdd2_S	3	Assigned to SSW_JFET1 of SpSLWJfetBias command
12	SSW_Gnd	3	Connected internally to Gnd_Bias_Sp
13	Pbias_SSW	3	Assigned to SW of SpectroBiasAmpl command
14	Vdd3_Vss3_S_SHD		Connected internally to Gnd_Bias_Sp
15	Vss3_S	3	Assigned to VSS2 of SpSWJfetVSS command
16	PHeater_TC	3	Connected internally to Gnd_Bias_Ph
17	PHeater_SLW	3	Connected internally to Gnd_Bias_Sp
18	Heater_SSW_SHD	3	Assigned to SW of SpectroBiasAmpl command
19	Nheater_SSW	3	Assigned to SpectroHeaterBias
20	NBias_TC	3	Assigned to TC of PhotoBiasAmpl command
21	Vdd_TC	3	Assigned to TC_JFET of PhSWJfetPWR command
22	Pbias_SLW	3	Assigned to LW of SpectroBiasAmpl command
23	Bias_SLW_SHD		
24	NBias_SLW	3	Assigned to LW of SpectroBiasAmpl command
25	Vdd1_S	3	Assigned to SLW_JFET1 of SpSLWJfetPWR command
26			
27	Vss1_S	3	Assigned to VSS of SpLWJfetVSS command
28	PBias_SSW	3	Assigned to SW of SpectroBiasAmpl command
29	Vdd2_Vss2_S_SHD		Connected internally to Gnd_Bias_Sp
30	Vss2_S	3	Assigned to VSS1 of SpSWJfetVSS command
31	Bias_SSW_SHD		Connected internally to Gnd_Bias_Sp
32	NBias_SSW	3	
33	Vdd3_S	3	Assigned to SSW_JFET2 of SpSLWJfetPWR command
34	Faraday_shield link		
35	Nheater_TC	3	Assigned to PhotoHeaterBias
36	Nheater_SLW	3	Assigned to SpectroHeaterBias
37	Pheater_SSW		Connected internally to Gnd_Bias_Sp

Note: all xx_SHD are onnected to connector body

Unit : DCU
 Sub-unit/Module : BIAS_P (Redundant)
 Connector Identifier : J30
 Connector Type : DDMA78S
 Connector Name : HSDCU_J30

Pin#	Signal Name	EMC Class	Signal Description
1	Vdd1_P	3	Assigned to P250_JFET1 of PhSWJfetBias command
2	Vss1_P	3	Assigned to VSS1 of PhSWJfetVSS command
3	Vdd2_P	3	Assigned to P250_JFET2 of PhSWJfetBias command
4	Vdd3_P	3	Assigned to P250_JFET3 of PhSWJfetBias command
5	Vss3_P	3	Assigned to VSS3 of PhSWJfetVSS command
6	PBias_P250	3	Assigned to P250 of PhotoBiasAmpl command
7	FPU_Faraday_shield		
8	Pheater_PSW1	3	Connected internally to Gnd_Bias_Ph
9	Nheater_PSW1	3	Assigned to PhotoHeaterVolt of PhotoHeater command
10	Vdd7_P	3	Assigned to P350_JFET1 of PhMLWJfetBias command
11	Vss7_P	3	Assigned to VSS1 of PhMWJfetVSS command
12	Vdd8_P	3	Assigned to P350_JFET2 of PhMLWJfetBias command
13	NBias_P350	3	Assigned to P350 of PhotoBiasAmpl command
14	Pbias_P350	3	Assigned to P350 of PhotoBiasAmpl command
15	Nheater_PMW1	3	Assigned to PhotoHeaterVolt of PhotoHeater command
16	Pheater_PMW1	3	Connected internally to Gnd_Bias_Ph
17	Vss11_P	3	Assigned to VSS1 of PhLWJfetVSS command
18	Vdd12_P	3	Assigned to P500_JFET2 of PhMLWJfetBias command
19	Vss12_P	3	Assigned to VSS2 of PhLWJfetVSS command
20	Pheater_PLW1	3	Connected internally to Gnd_Bias_Ph
21	Vdd1_Vss1_P_SHD		Connected internally to Gnd_Bias_Ph
22	Vdd2_Vss2_P_SHD		Connected internally to Gnd_Bias_Ph
23	Vss2_P	3	Assigned to VSS2 of PhSWJfetVSS command
24	Vdd3_Vss3_P_SHD		Connected internally to Gnd_Bias_Ph
25	Bias_P250_SHD		Connected internally to Gnd_Bias_Ph
26	Nbias_250	3	Assigned to P250 of PhotoBiasAmpl command
27	PSW_Gnd		Connected internally to Gnd_Bias_Ph
28	Heater_PSW1_SHD		Connected internally to Gnd_Bias_Ph
29	PheaterPSW2	3	Connected internally to Gnd_Bias_Ph
30	Vdd7_Vss7_P_SHD		Connected internally to Gnd_Bias_Ph
31	Vss8_P	3	Assigned to VSS2 of PhMWJfetVSS command
32	Vdd8_Vss8_P_SHD		Connected internally to Gnd_Bias_Ph
33	Bias_P350_SHD		Connected internally to Gnd_Bias_Ph
34	PMW_Gnd		
35	Heater_PMW1_SHD		Connected internally to Gnd_Bias_Ph
36	Vdd11_P	3	Assigned to P500_JFET1 of PhMLWJfetBias command
37	Vdd11_Vss11_P_SHD		Connected internally to Gnd_Bias_Ph
38	Vdd12_Vss12_P_SHD		Connected internally to Gnd_Bias_Ph
39	Nheater_PLW1	3	Assigned to PhotoHeaterVolt of PhotoHeater command
40	Vdd4_Vss4_P_SHD		Connected internally to Gnd_Bias_Ph
41	Vdd4_P	3	Assigned to P250_JFET4 of PhSWJfetBias command
42	Vdd5_Vss5_P_SHD		Connected internally to Gnd_Bias_Ph

43	Vdd6_Vss6_P_SHD		Connected internally to Gnd_Bias_Ph
44	Vss6_P	3	Assigned to VSS6 of PhSWJfetVSS command
45	Bias_P250_SHD		Connected internally to Gnd_Bias_Ph
46	Bias_P250_SHD		Connected internally to Gnd_Bias_Ph
47	Pbias_P250	3	Assigned to P250 of PhotoBiasAmpl command
48	Heater_PSW2_3_SHD		Connected internally to Gnd_Bias_Ph
49	Nheater_PSW2	3	Assigned to PhotoHeaterVolt of PhotoHeater command
50	Vdd9_Vss9_P_SHD		Connected internally to Gnd_Bias_Ph
51	Vdd10_Vss10_P_SHD		Connected internally to Gnd_Bias_Ph
52	Vss10_P	3	Assigned to VSS4 of PhMWJfetVSS command
53	Bias_P350_SHD		Connected internally to Gnd_Bias_Ph
54	Pheater_PMW2	3	Connected internally to Gnd_Bias_Ph
55	Heater_PMW2_SHD		Connected internally to Gnd_Bias_Ph
56	Bias_P500_SHD		Connected internally to Gnd_Bias_Ph
57	Nbias_P500	3	Assigned to P500 of PhotoBiasAmpl command
58	Bias_P500_SHD		Connected internally to Gnd_Bias_Ph
59	Heater_PLW1_SHD		Connected internally to Gnd_Bias_Ph
60	Vss4_P	3	Assigned to VSS4 of PhSWJfetVSS command
61	Vdd5_P	3	Assigned to P250_JFET5 of PhSWJfetBias command
62	Vss5_P	3	Assigned to VSS5 of PhSWJfetVSS command
63	Vdd6_P	3	Assigned to P250_JFET6 of PhSWJfetBias command
64	Nbias_P250	3	Assigned to P250 of PhotoBiasAmpl command
65	Pbias_P250	3	Assigned to P250 of PhotoBiasAmpl command
66	Nbias_P250	3	Assigned to P250 of PhotoBiasAmpl command
67	Nheater_PSW3	3	Assigned to PhotoHeaterVolt of PhotoHeater command
68	Pheater_PSW3		Connected internally to Gnd_Bias_Ph
69	Vdd9_P	3	Assigned to P350_JFET3 of PhMLWJfetBias command
70	Vss9_P	3	Assigned to VSS3 of PhMWJfetVSS command
71	Vdd10_P	3	Assigned to P350_JFET4 of PhMLWJfetBias command
72	Nbias_P350	3	Assigned to P350 of PhotoBiasAmpl command
73	Pbias_P350	3	Assigned to P350 of PhotoBiasAmpl command
74	Nheater_PMW2	3	Assigned to PhotoHeaterVolt of PhotoHeater command
75	Pbias_P500	3	Assigned to P500 of PhotoBiasAmpl command
76	Nbias_P500	3	Assigned to P500 of PhotoBiasAmpl command
77	Pbias_P500	3	Assigned to P500 of PhotoBiasAmpl command
78	PLW_gnd		

Note: all xx_SHD are onnected to connector body

Unit : DCU
 Sub-unit/Module : BIAS_S (Redundant)
 Connector Identifier : J32
 Connector Type : DCMA37S
 Connector Name : HSDCU_J32

Pin#	Signal Name	EMC Class	Signal Description
1	PBias_TC	3	Assigned to TC of PhotoBiasAmpl command
2	Bias_TC_SHD		Connected internally to Gnd_Bias_Ph
3	Vss_TC	3	Assigned to TC of PhSWJfetVss
4	Nbias_SLW	3	Assigned to LW of SpectroBiasAmpl command
5	Pbias_SLW	3	Assigned to LW of SpectroBiasAmpl command
6	SLW_Gnd_SHDs		Connected internally to Gnd_Bias_Sp
7	Vss1_S	3	Assigned to VSS of SpLWJfetVSS command
8	Vdd1_S	3	Assigned to SLW_JFET1 of SpSLWJfetPWR command
9	Bias_SSW_SHD		Connected internally to Gnd_Bias_Sp
10	NBias_SSW	3	Assigned to SW of SpectroBiasAmpl command
11	Vdd2_S	3	Assigned to SSW_JFET1 of SpSLWJfetBias command
12	SSW_Gnd	3	Connected internally to Gnd_Bias_Sp
13	Pbias_SSW	3	Assigned to SW of SpectroBiasAmpl command
14	Vdd3_Vss3_S_SHD		Connected internally to Gnd_Bias_Sp
15	Vss3_S	3	Assigned to VSS2 of SpSWJfetVSS command
16	PHeater_TC	3	Connected internally to Gnd_Bias_Ph
17	PHeater_SLW	3	Connected internally to Gnd_Bias_Sp
18	Heater_SSW_SHD	3	Assigned to SW of SpectroBiasAmpl command
19	Nheater_SSW	3	Assigned to SpectroHeaterBias
20	NBias_TC	3	Assigned to TC of PhotoBiasAmpl command
21	Vdd_TC	3	Assigned to TC_JFET of PhSWJfetPWR command
22	Pbias_SLW	3	Assigned to LW of SpectroBiasAmpl command
23	Bias_SLW_SHD		
24	NBias_SLW	3	Assigned to LW of SpectroBiasAmpl command
25	Vdd1_S	3	Assigned to SLW_JFET1 of SpSLWJfetPWR command
26			
27	Vss1_S	3	Assigned to VSS of SpLWJfetVSS command
28	PBias_SSW	3	Assigned to SW of SpectroBiasAmpl command
29	Vdd2_Vss2_S_SHD		Connected internally to Gnd_Bias_Sp
30	Vss2_S	3	Assigned to VSS1 of SpSWJfetVSS command
31	Bias_SSW_SHD		Connected internally to Gnd_Bias_Sp
32	NBias_SSW	3	
33	Vdd3_S	3	Assigned to SSW_JFET2 of SpSLWJfetPWR command
34	Faraday_shield link		
35	Nheater_TC	3	Assigned to PhotoHeaterBias
36	Nheater_SLW	3	Assigned to SpectroHeaterBias
37	Pheater_SSW		Connected internally to Gnd_Bias_Sp

Note: all xx_SHD are onnected to connector body

5.4.3.2. MCU Interfaces

5.4.3.2.1. SMEC Module

Unit : FCU
 Sub-unit : MCU/SMEC (Main)
 Connector Identifier : J17
 Connector Type : DCMA37S
 Connector Name : HSFCU_J17

Pin #	Signal name	EMC class	Signal Description
1	S_Mot_Coil_P	3	SMEC drive coil I+
2	S_Mot_Coil_N	3	SMEC drive coil I-
20	S_Mot_Coil_SHD		SMEC drive coil shield
4	S_Mot_Bemf_P	3	SMEC drive coil supply sense
5	S_Mot_Bemf_N	3	SMEC drive coil return sense
23	S_Mot_Bemf_SHD		SMEC drive coil supply sense shield
6	FPU Faraday Shield		Connected FPU side only
7	LEDA	3	SMEC position sensor Led power supply
8	LEDC	3	SMEC position sensor Led power return
26	LED_SHD		Shield
10	IPD1A	3	SMEC position sensor photodiode #1 I+
11	IPD1C	3	SMEC position sensor photodiode #1 I-
29	IPD1_SHD		Shield
13	IPD2A	3	SMEC position sensor photodiode #2 I+
14	IPD2C	3	SMEC position sensor photodiode #2 I-
32	IPD2_SHD		Shield
16	IPD3A	3	SMEC position sensor photodiode #3 I+
17	IPD3C	3	SMEC position sensor photodiode #3 I-
35	IPD3_SHD		Shield
21	S_Mot_Coil_P	3	SMEC drive coil I+ (rob)
22	S_Mot_Coil_N	3	SMEC drive coil I- (rob)
3	S_Mot_Coil_SHD		SMEC drive coil shield rob)
24			NC
25			NC
27	N3V_PSense_PWR	3	SMEC position sensor power supply
28	N3V_Psense_RTN	3	SMEC position sensor power return
9	POS_POWER_SHD		Shield
30	CRPD1A	3	SMEC pos. sensor photodiode #1 feedback +
31	CRPD1C	3	SMEC pos. sensor photodiode #1 feedback -
12	CRPD1_SHD		Shield
33	CRPD2A	3	SMEC pos. sensor photodiode #2 feedback +
34	CRPD2C	3	SMEC pos. sensor photodiode #2 feedback -
15	CRPD2_SHD		Shield
36	CRPD3A	3	SMEC pos. sensor photodiode #3 feedback +
37	CRPD3C	3	SMEC pos. sensor photodiode #3 feedback -
18	CRPD3_SHD		Shield
19			NC

Unit : FCU
Sub-unit : MCU/SMEC (Redundant)
Connector Identifier : J18
Connector Type : DCMA37S
Connector Name : HSFCU_J18

Pin #	Signal name	EMC Class	Signal Description
1	S_Mot_Coil_P	3	SMEC drive coil I+
2	S_Mot_Coil_N	3	SMEC drive coil I-
20	S_Mot_Coil_SHD		SMEC drive coil shield
4	S_Mot_Bemf_P	3	SMEC drive coil supply sense
5	S_Mot_Bemf_N	3	SMEC drive coil return sense
23	S_Mot_Bemf_SHD		SMEC drive coil supply sense shield
6	FPU Faraday Shield		Connected FPU side only
7	LEDA	3	SMEC position sensor Led power supply
8	LEDC	3	SMEC position sensor Led power return
26	LED_SHD		Shield
10	IPD1A	3	SMEC position sensor photodiode #1 I+
11	IPD1C	3	SMEC position sensor photodiode #1 I-
29	IPD1_SHD		Shield
13	IPD2A	3	SMEC position sensor photodiode #2 I+
14	IPD2C	3	SMEC position sensor photodiode #2 I-
32	IPD2_SHD		Shield
16	IPD3A	3	SMEC position sensor photodiode #3 I+
17	IPD3C	3	SMEC position sensor photodiode #3 I-
35	IPD3_SHD		Shield
21	S_Mot_Coil_P	3	SMEC drive coil I+ (rob)
22	S_Mot_Coil_N	3	SMEC drive coil I- (rob)
3	S_Mot_Coil_SHD		SMEC drive coil shield rob)
24			NC
25			NC
27	N3V_PSense_PWR	3	SMEC position sensor power supply
28	N3V_Psense_RTN	3	SMEC position sensor power return
9	POS_POWER_SHD		Shield
30	CRPD1A	3	SMEC pos. sensor photodiode #1 feedback +
31	CRPD1C	3	SMEC pos. sensor photodiode #1 feedback -
12	CRPD1_SHD		Shield
33	CRPD2A	3	SMEC pos. sensor photodiode #2 feedback +
34	CRPD2C	3	SMEC pos. sensor photodiode #2 feedback -
15	CRPD2_SHD		Shield
36	CRPD3A	3	SMEC pos. sensor photodiode #3 feedback +
37	CRPD3C	3	SMEC pos. sensor photodiode #3 feedback -
18	CRPD3_SHD		Shield
19			NC

Unit : FCU
 Sub-unit : MCU/SMEC (Main)
 Connector Identifier : J29
 Connector Type : DCMA37P
 Connector Name : HSFCU_J29

Pin #	Signal name	EMC Class	Signal Description
1	S_LL#1_Coil_P_A	3	SMEC launch latch #1 power supply
2	S_LL#1_Coil_N_A	3	SMEC launch latch #1 power return
3	S_LL#1_Coil_SHD_B		Shield
4	S_LL#2_Coil_P_A	3	SMEC launch latch #2 power supply
5	S_LL#2_Coil_N_A	3	SMEC launch latch #2 power return
6	S_LL#2_Coil_SHD_B		Shield
7			NC
8			NC
10			NC
11			NC
12			NC
13	LVDT_PRIM_P	3	SMEC LVDT primary coil power supply (P)
14	LVDT_PRIM_N	3	SMEC LVDT primary coil power supply (N)
15	LVDT_SECA_P	3	SMEC LVDT secondary coil # 1 signal (P)
16	LVDT_SECA_N	3	SMEC LVDT secondary coil # 1 signal (N)
17	LVDT_SECB_P	3	SMEC LVDT secondary coil # 2 signal (P)
18	LVDT_SECB_N	3	SMEC LVDT secondary coil # 2 signal (N)
19			NC
20	S_LL#1_Coil_SHD_A		Shield
21	S_LL#1_Coil_P_B	3	SMEC launch latch #1 power supply
22	S_LL#1_Coil_N_B	3	SMEC launch latch #1 power return
23	S_LL#2_Coil_SHD_A		Shield
24	S_LL#2_Coil_P_B	3	SMEC launch latch #2 power supply
25	S_LL#2_Coil_N_B	3	SMEC launch latch #2 power return
26			NC
27			NC
28			NC
29			NC
30			NC
31			NC
32	LVDT_PRIM_SHD		Shield
33			NC
34	LVDT_SECA_SHD		Shield
35			NC
36	LVDT_SECB_SHD		Shield
37			NC

Unit : FCU
 Sub-unit : MCU/SMEC (Redundant)
 Connector Identifier : J30
 Connector Type : DCMA37P
 Connector Name : HSFCU_J30

Pin #	Signal name	EMC Class	Signal Description
1	S_LL#1_Coil_P_A	3	SMEC launch latch #1 power supply
2	S_LL#1_Coil_N_A	3	SMEC launch latch #1 power return
3	S_LL#1_Coil_SHD_B		Shield
4	S_LL#2_Coil_P_A	3	SMEC launch latch #2 power supply
5	S_LL#2_Coil_N_A	3	SMEC launch latch #2 power return
6	S_LL#2_Coil_SHD_B		Shield
7			NC
8			NC
10			NC
11			NC
12			NC
13	LVDT_PRIM_P	3	SMEC LVDT primary coil power supply (P)
14	LVDT_PRIM_N	3	SMEC LVDT primary coil power supply (N)
15	LVDT_SECA_P	3	SMEC LVDT secondary coil # 1 signal (P)
16	LVDT_SECA_N	3	SMEC LVDT secondary coil # 1 signal (N)
17	LVDT_SECB_P	3	SMEC LVDT secondary coil # 2 signal (P)
18	LVDT_SECB_N	3	SMEC LVDT secondary coil # 2 signal (N)
19			NC
20	S_LL#1_Coil_SHD_A		Shield
21	S_LL#1_Coil_P_B	3	SMEC launch latch #1 power supply
22	S_LL#1_Coil_N_B	3	SMEC launch latch #1 power return
23	S_LL#2_Coil_SHD_A		Shield
24	S_LL#2_Coil_P_B	3	SMEC launch latch #2 power supply
25	S_LL#2_Coil_N_B	3	SMEC launch latch #2 power return
26			NC
27			NC
28			NC
29			NC
30			NC
31			NC
32	LVDT_PRIM_SHD		Shield
33			NC
34	LVDT_SECA_SHD		Shield
35			NC
36	LVDT_SECB_SHD		Shield
37			NC

5.4.3.2.2. BSM Module

Unit : FCU
 Sub-unit : MCU/BSM (Main)
 Connector Identifier : J19
 Connector Type : DCMA37S
 Connector Name : HSFCU_J19

Pin #	Name	EMC Class	Signal Description
1	Ch Sens Sup	3	Chop sensor supply
2	Ch Sens Sup Meas	3	Chop sensor supply sense
3	Ch Sens RTN Meas	3	Chop sensor return sense
4	Jig Sens Sup	3	Jiggle sensor supply
5	Jig Sens Sup Meas	3	Jiggle sensor supply sense
6	Jig Sens RTN Meas	3	Jiggle sensor return sense
7			Reserved
8			Reserved
9			NC
10			Reserved
11			Reserved
12			NC
13	B LL Sup	3	Launch latch coil supply
14	B LL RTN	3	Launch latch coil return
15	Ch Mot Sup	3	Chop motor supply
16	Ch Bemf Meas P	3	Chop motor supply sense
17	Ch Mot SHD		Chop motor screen
18	Jig Mot RTN	3	Jiggle motor return
19	Jig Bemf Meas N	3	Jiggle motor return sense
20	Ch Sens RTN	3	Chop sensor return
21	Ch Sens O/P	3	Chop sensor o/p
22	Ch Sens SHD1		Chop sensor supply screen
23	Jig Sens Ret	3	Jiggle sensor return
24	Jig Sens O/P	3	Jiggle sensor o/p
25			Reserved
26			Reserved
27			Reserved
28			Reserved
29			Reserved
30			NC
31			NC
32			NC
33	LL SHD		Launch latch coil screen
34	Ch Mot RTN	3	Chop motor return
35	Ch Bemf Meas N	3	Chop motor return sense
36	Jig Mot Sup	3	Jiggle motor supply
37	Jig Bemf Meas P	3	Jiggle motor supply sense

Unit : FCU
 Sub-unit : MCU/BSM (Redundant)
 Connector Identifier : J20
 Connector Type : DCMA37S
 Connector Name : HSFCU_J20

Pin #	Name	EMC Class	Signal function
1	Ch Sens Sup	3	Chop sensor supply
2	Ch Sens Sup Meas	3	Chop sensor supply sense
3	Ch Sens RTN Meas	3	Chop sensor return sense
4	Jig Sens Sup	3	Jiggle sensor supply
5	Jig Sens Sup Meas	3	Jiggle sensor supply sense
6	Jig Sens RTN Meas	3	Jiggle sensor return sense
7			Reserved
8			Reserved
9			NC
10			Reserved
11			Reserved
12			NC
13	B LL Sup	3	Launch latch coil supply
14	B LL RTN	3	Launch latch coil return
15	Ch Mot Sup	3	Chop motor supply
16	Ch Bemf Meas P	3	Chop motor supply sense
17	Ch Mot SHD		Chop motor screen
18	Jig Mot RTN	3	Jiggle motor return
19	Jig Bemf Meas N	3	Jiggle motor return sense
20	Ch Sens RTN	3	Chop sensor return
21	Ch Sens O/P	3	Chop sensor o/p
22	Ch Sens SHD1		Chop sensor supply screen
23	Jig Sens Ret	3	Jiggle sensor return
24	Jig Sens O/P	3	Jiggle sensor o/p
25			Reserved
26			Reserved
27			Reserved
28			Reserved
29			Reserved
30			NC
31			NC
32			NC
33	LL SHD		Launch latch coil screen
34	Ch Mot RTN	3	Chop motor return
35	Ch Bemf Meas N	3	Chop motor return sense
36	Jig Mot Sup	3	Jiggle motor supply
37	Jig Bemf Meas P	3	Jiggle motor supply sense

5.4.3.3. SCU Interfaces

5.4.3.3.1. TEMP Modules

Unit : FCU
 Sub-unit/Module : SCU/TEMP (Main)
 Connector Identifier : J21
 Connector Type : DAMA15S
 Connector Name : HSFCU_J21
 Harness Identifier : I11 SVM11-DRCU11 AUX-P

Pin#	Signal Name	EMC Class	Signal Description
1	T_BSMM_1_D+	3	BSM mechanism temperature drive+
9	T_BSMM_1_S+	3	BSM mechanism temperature sensor sense+
10	T_BSMM_1_S-	3	BSM mechanism temperature sensor sense-
2	T_BSMM_1_D-	3	BSM mechanism temperature drive-
3	T_BSMM_1_SHD*		BSM mechanism temperature shield
4	T_FTSM_1_D+	3	SMEC mechanism temperature drive+
11	T_FTSM_1_S+	3	SMEC mechanism temperature sensor sense+
12	T_FTSM_1_S-	3	SMEC mechanism temperature sensor sense-
5	T_FTSM_1_D-	3	SMEC mechanism temperature drive-
13	T_FTSM_1_SHD*		SMEC mechanism temperature shield
6	T_FTSS_1_D+	3	SMEC/SOB I/F temperature drive+
14	T_FTSS_1_S+	3	SMEC/SOB I/F temperature sensor sense+
15	T_FTSS_1_S-	3	SMEC/SOB I/F temperature sensor sense-
7	T_FTSS_1_D-	3	SMEC/SOB I/F temperature drive-
8	T_FTSS_1_SHD*		SMEC/SOB I/F temperature shield

*: all xx_SHD are connected to connector body

Unit : FCU
 Sub-unit/Module : SCU/TEMP (Main)
 Connector Identifier : J23
 Connector Type : DDMA50S
 Connector Name : HSFCU_J23
 Harness Identifier : I10 SVM10-DRCU10 AUX-P

Pin#	Signal Name	EMC Class	Signal Description
1	T_CEV_1_D+	3	Evaporator temperature (300 mK) drive+
2	T_CEV_1_D-	3	Evaporator temperature (300 mK) drive-
18	T_CEV_1_S+	3	Evaporator temperature (300 mK) sense+
35	T_CEV_1_S-	3	Evaporator temperature (300 mK) sense-
34	T_CEV_1_SHD*		Evaporator temperature (300 mK) shield
3	T_CPHP_1_D+	3	Sorption Pump temperature drive+
19	T_CPHP_1_D-	3	Sorption Pump temperature drive-
20	T_CPHP_1_S+	3	Sorption Pump temperature sensor sense+
36	T_CPHP_1_S-	3	Sorption Pump temperature sensor sense-
4	T_CPHS_1_D+	3	Sorption Pump HS temperature drive+
5	T_CPHS_1_D-	3	Sorption Pump HS temperature drive-
21	T_CPHS_1_S+	3	Sorption Pump HS temperature sensor sense+
37	T_CPHS_1_S-	3	Sorption Pump HS temperature sensor sense-
38	T_TP_1_SHDA*		Cooler temperature probe shields
6	T_CEHS_1_D+	3	Evaporator HS temperature drive+
22	T_CEHS_1_D-	3	Evaporator HS temperature drive-
23	T_CEHS_1_S+	3	Evaporator HS temperature sensor sense+
39	T_CEHS_1_S-	3	Evaporator HS temperature sensor sense-
7	T_CSHT_1_D+	3	Thermal Shunt temperature drive+
8	T_CSHT_1_D-	3	Thermal Shunt temperature drive-
24	T_CSHT_1_S+	3	Thermal Shunt temperature sensor sense+
40	T_CSHT_1_S-	3	Thermal Shunt temperature sensor sense-
41	FPU Faraday Shield Link		NC FCU side
9	T_SOBS_1_D+	3	SOB temperature drive+
25	T_SOBS_1_D-	3	SOB temperature drive-
26	T_SOBS_1_S+	3	SOB temperature sensor sense+
42	T_SOBS_1_S-	3	SOB temperature sensor sense-
43	T_TP_1_SHDB*		SOB & Spect. Det. Box probe shields
10	T_SL0_1_D+	3	Spect. Det. Box temperature drive+
11	T_SL0_1_D-	3	Spect. Det. Box temperature drive-
27	T_SL0_1_S+	3	Spect. Det. Box temperature sensor sense+
44	T_SL0_1_S-	3	Spect. Det. Box temperature sensor sense-
12	T_PL0_1_D+	3	Phot. Det. Box temperature drive+
28	T_PL0_1_D-	3	Phot. Det. Box temperature drive-
29	T_PL0_1_S+	3	Phot. Det. Box temperature sensor sense+
45	T_PL0_1_S-	3	Phot. Det. Box temperature sensor sense-
46	T_TP_1_SHDC*		Phot. Det. Box & Opt. S/bench shields
13	T_SUB_1_D+	3	Optical Sub-bench temperature drive+
14	T_SUB_1_D-	3	Optical Sub-bench temperature drive-
30	T_SUB_1_S+	3	Optical Sub-bench temperature sensor sense+

47	T_SUB_1_S-	3	Optical Sub-bench temperature sensor sense-
15	T_BAF_1_D+	3	FPU Input Baffle temperature drive+
31	T_BAF_1_D-	3	FPU Input Baffle temperature drive-
32	T_BAF_1_S+	3	FPU Input Baffle temperature sensor sense+
48	T_BAF_1_S-	3	FPU Input Baffle temperature sensor sense-
49	T_TP_1_SHDD*		FPU i/p baffle & BSM/SOB I/F shields
16	T_BSMS_1_D+	3	BSM/SOB I/F temperature drive+
17	T_BSMS_1_D-	3	BSM/SOB I/F temperature drive-
33	T_BSMS_1_S+	3	BSM/SOB I/F temperature sensor sense+
50	T_BSMS_1_S-	3	BSM/SOB I/F temperature sensor sense-

*: all xx_SHD are onected to connector body

Unit : FCU
 Sub-unit/Module : SCU/TEMP (Main)
 Connector Identifier : J25
 Connector Type : DAMA15S
 Connector Name : HSFCU_J25
 Harness Identifier : I10 SVM10-DRCU10 AUX-P

Pin#	Signal Name	EMC Class	Signal Description
1	T_SCST_1_D+	3	Spect. Stim. Flange temperature drive+
9	T_SCST_1_D-	3	Spect. Stim. Flange temperature drive-
2	T_SCST_1_S+	3	Spect. Stim. Flange temperature sensor sense+
10	T_SCST_1_S-	3	Spect. Stim. Flange temperature sensor sense-
3	T_SCST_1_SHD*		Spect. Stim. Flange shield
4	T_SCL4_1_D+	3	HS Spect. Stim. 4% temperature drive+
11	T_SCL4_1_D-	3	HS Spect. Stim. 4% temperature drive-
5	T_SCL4_1_S+	3	HS Spect. Stim. 4% temperature sensor sense+
12	T_SCL4_1_S-	3	HS Spect. Stim. 4% temperature sensor sense-
13	T_SCL_1_SHD*		HS Spect. Stim. 4% & 2% shield
6	T_SCL2_1_D+	3	HS Spect. Stim. 2% temperature drive+
14	T_SCL2_1_D-	3	HS Spect. Stim. 2% temperature drive-
7	T_SCL2_1_S+	3	HS Spect. Stim. 2% temperature sensor sense+
15	T_SCL2_1_S-	3	HS Spect. Stim. 2% temperature sensor sense-
8			NC

*: all xx_SHD are onected to connector body

Unit : FCU
 Sub-unit/Module : SCU/TEMP (Redundant)
 Connector Identifier : J22
 Connector Type : DAMA15S
 Connector Name : HSFCU_J22
 Harness Identifier : I13 SVM13-DRCU13 DRV-R

Pin#	Signal Name	EMC Class	Signal Description
1	T_BSMM_2_D+	3	BSM mechanism temperature sensor drive+
9	T_BSMM_2_S+	3	BSM mechanism temperature sensor sense+
10	T_BSMM_2_S-	3	BSM mechanism temperature sensor sense-
2	T_BSMM_2_D-	3	BSM mechanism temperature sensor drive-
3	T_BSMM_2_SHD*		BSM mechanism temperature shield
4	T_FTSM_2_D+	3	SMEC mechanism temperature sensor drive+
11	T_FTSM_2_S+	3	SMEC mechanism temperature sensor sense+
12	T_FTSM_2_S-	3	SMEC mechanism temperature sensor sense-
5	T_FTSM_2_D-	3	SMEC mechanism temperature sensor drive-
13	T_FTSM_2_SHD*		SMEC mechanism temperature shield
6	T_FTSS_2_D+	3	SMEC/SOB I/F temperature sensor drive+
14	T_FTSS_2_S+	3	SMEC/SOB I/F temperature sensor sense+
15	T_FTSS_2_S-	3	SMEC/SOB I/F temperature sensor sense-
7	T_FTSS_2_D-	3	SMEC/SOB I/F temperature sensor drive-
8	T_FTSS_2_SHD*		SMEC/SOB I/F temperature shield

*: all xx_SHD are connected to connector body

Unit : FCU
 Sub-unit/Module : SCU/TEMP (Redundant)
 Connector Identifier : J24
 Connector Type : DDMA50S
 Connector Name : HSFCU_J24
 Harness Identifier : I12 SVM12-DRCU12 AUX-R

Pin#	Signal Name	EMC Class	Signal Description
1	T_CEV_2_D+	3	Evaporator temperature (300 mK) drive+
2	T_CEV_2_D-	3	Evaporator temperature (300 mK) drive-
18	T_CEV_2_S+	3	Evaporator temperature (300 mK) sense+
35	T_CEV_2_S-	3	Evaporator temperature (300 mK) sense-
34	T_CEV_2_SHD*		Evaporator temperature (300 mK) shield
3	T_CPHP_2_D+	3	Sorption Pump temperature sensor drive+
19	T_CPHP_2_D-	3	Sorption Pump temperature sensor drive-
20	T_CPHP_2_S+	3	Sorption Pump temperature sensor sense+
36	T_CPHP_2_S-	3	Sorption Pump temperature sensor sense-
4	T_CPHS_2_D+	3	Sorption Pump HS temperature sensor drive+
5	T_CPHS_2_D-	3	Sorption Pump HS temperature sensor drive-
21	T_CPHS_2_S+	3	Sorption Pump HS temperature sensor sense+
37	T_CPHS_2_S-	3	Sorption Pump HS temperature sensor sense-
38	T_TP_2_SHDA*		Cooler temperature probe shields
6	T_CEHS_2_D+	3	Evaporator HS temperature sensor drive+
22	T_CEHS_2_D-	3	Evaporator HS temperature sensor drive-
23	T_CEHS_2_S+	3	Evaporator HS temperature sensor sense+
39	T_CEHS_2_S-	3	Evaporator HS temperature sensor sense-
7	T_CSHT_2_D+	3	Thermal Shunt temperature sensor drive+
8	T_CSHT_2_D-	3	Thermal Shunt temperature sensor drive-
24	T_CSHT_2_S+	3	Thermal Shunt temperature sensor sense+
40	T_CSHT_2_S-	3	Thermal Shunt temperature sensor sense-
41	FPU Faraday Shield Link		NC FC side
9	T_SOB_2_D+	3	SOB temperature sensor drive+
25	T_SOB_2_D-	3	SOB temperature sensor drive-
26	T_SOB_2_S+	3	SOB temperature sensor sense+
42	T_SOB_2_S-	3	SOB temperature sensor sense-
43	T_TP_2_SHDB*		SOB & Spect. Det. Box probe shields
10	T_SL0_2_D+	3	Spect. Det. Box temperature sensor drive+
11	T_SL0_2_D-	3	Spect. Det. Box temperature sensor drive-
27	T_SL0_2_S+	3	Spect. Det. Box temperature sensor sense+
44	T_SL0_2_S-	3	Spect. Det. Box temperature sensor sense-
12	T_PL0_2_D+	3	Phot. Det. Box temperature sensor drive+
28	T_PL0_2_D-	3	Phot. Det. Box temperature sensor drive-
29	T_PL0_2_S+	3	Phot. Det. Box temperature sensor sense+
45	T_PL0_2_S-	3	Phot. Det. Box temperature sensor sense-
46	T_TP_2_SHDC*		Phot. Det. Box & Opt. S/bench shields
13	T_SUB_2_D+	3	Optical Sub-bench temperature sensor drive+
14	T_SUB_2_D-	3	Optical Sub-bench temperature sensor drive-
30	T_SUB_2_S+	3	Optical Sub-bench temperature sensor sense+

47	T_SUB_2_S-	3	Optical Sub-bench temperature sensor sense-
15	T_BAF_2_D+	3	FPU Input Baffle temperature sensor drive+
31	T_BAF_2_D-	3	FPU Input Baffle temperature sensor drive
32	T_BAF_2_S+	3	FPU Input Baffle temperature sensor sense+
48	T_BAF_2_S-	3	FPU Input Baffle temperature sensor sense-
49	T_TP_2_SHDD*		FPU i/p baffle & BSM/SOB I/F shields
16	T_BSMS_2_D+	3	BSM/SOB I/F temperature sensor drive+
17	T_BSMS_2_D-	3	BSM/SOB I/F temperature sensor drive-
33	T_BSMS_2_S+	3	BSM/SOB I/F temperature sensor sense+
50	T_BSMS_2_S-	3	BSM/SOB I/F temperature sensor sense-

*all xx_SHD are onnected to connector body

Unit : FCU
 Sub-unit/Module : SCU/TEMP (Redundant)
 Connector Identifier : J26
 Connector Type : DAMA15S
 Connector Name : HSFCU_J26
 Harness Identifier : I12 SVM12-DRCU12 AUX-R

Pin#	Signal Name	EMC Class	Signal Description
1	T_SCST_2_D+	3	Spect. Stim. Flange temperature sensor drive+
9	T_SCST_2_D-	3	Spect. Stim. Flange temperature sensor drive-
2	T_SCST_2_S+	3	Spect. Stim. Flange temperature sensor sense+
10	T_SCST_2_S-	3	Spect. Stim. Flange temperature sensor sense-
3	T_SCST_2_SHD*		Spect. Stim. Flange shield
4	T_SCL4_2_D+	3	HS Spect. Stim. 4% temperature sensor drive+
11	T_SCL4_2_D-	3	HS Spect. Stim. 4% temperature sensor drive-
5	T_SCL4_2_S+	3	HS Spect. Stim. 4% temperature sensor sense+
12	T_SCL4_2_S-	3	HS Spect. Stim. 4% temperature sensor sense-
13	T_SCL_2_SHD*		HS Spect. Stim. 4% & 2% shield
6	T_SCL2_2_D+	3	HS Spect. Stim. 2% temperature sensor drive+
14	T_SCL2_2_D-	3	HS Spect. Stim. 2% temperature sensor drive-
7	T_SCL2_2_S+	3	HS Spect. Stim. 2% temperature sensor sense+
15	T_SCL2_2_S-	3	HS Spect. Stim. 2% temperature sensor sense-
8			NC

*all xx_SHD are onnected to connector body

5.4.3.3.2. CCHK_IF Modules

Unit : FCU
 Sub-unit/Module : SCU/CCHK (Main)
 Connector Identifier : J11
 Connector Type : DBMA25S
 Connector Name : HSFCU_J11

Pin #	Signal Name	EMC Class	Signal Description
1	SPheater_D+A	3	Sorption Pump heater I+_A
2	SPheater_D+B	3	Sorption Pump heater I+_B
14	SPheater_D-A	3	Sorption Pump heater I-_A
15	SPheater_D-B	3	Sorption Pump heater I-_B
3	SPHSheater_D+A	3	Sorption Pump Heat Switch heater I+_A
4	SPHSheater_D+B	3	Sorption Pump Heat Switch heater I+_B
16	SPHSheater_D-A	3	Sorption Pump Heat Switch heater I-_A
17	SPHSheater_D-B	3	Sorption Pump Heat Switch heater I-_B
5	EVHSheater_D+A	3	Evaporator Heat Switch heater I+_A
6	EVHSheater_D+B	3	Evaporator Heat Switch heater I+_B
18	EVHSheater_D-A	3	Evaporator Heat Switch heater I-_A
19	EVHSheater_D-B	3	Evaporator Heat Switch heater I-_B
7	Spect4heaterD+A	3	HS Spect. 4% heater I+_A
8	Spect4heaterD+B	3	HS Spect. 4% heater I+_B
20	Spect4heaterD-A	3	HS Spect. 4% heater I-_A
21	Spect4heaterD-B	3	HS Spect. 4% heater I-_B
9	Spect2heaterD+A	3	HS Spect. 2% heater I+_A
10	Spect2heaterD+B	3	HS Spect. 2% heater I+_B
22	Spect2heaterD-A	3	HS Spect. 2% heater I-_A
23	Spect2heaterD-B	3	HS Spect. 2% heater I-_B
11	TChheaterD+A	3	300-mK Thermal Control Heater I+_A
12	TChheaterD+B	3	300-mK Thermal Control Heater I+_B
24	TChheaterD-A	3	300-mK Thermal Control Heater I-_A
25	TChheaterD-B	3	300-mK Thermal Control Heater I-_B
13	TChheater_SHD		300-mK Thermal Control Heater shield.

Note: all xx_SHD are onnected to connector body

Unit : FCU
 Sub-unit/Module : SCU/CCHK (Main)
 Connector Identifier : J13
 Connector Type : DEMA9S
 Connector Name : HSFCU_J13

Pin#	Signal Name	EMC Class	Signal Description
1			
2	PhStimheaterD+A	3	Photometer Point Stim. heater I+_A
3	PhStimheaterD+B	3	Photometer Point Stim. heater I+_B
4	PhStimheater_SHD		Screen
5			
6			
7	PhStimheaterD+A	3	Photometer Point Stim. heater I-_A
8	PhStimheaterD+B	3	Photometer Point Stim. heater I-_B
9			

Note: all xx_SHD are onnected to connector body

Unit : FCU
 Sub-unit/Module : SCU/CCHK (Redundant)
 Connector Identifier : J12
 Connector Type : DBMA25S
 Connector Name : HSFCU_J12

Pin #	Signal Name	EMC Class	Signal Description
1	SPheater_D+A	3	Sorption Pump heater I+_A
2	SPheater_D+B	3	Sorption Pump heater I+_B
14	SPheater_D-A	3	Sorption Pump heater I-_A
15	SPheater_D-B	3	Sorption Pump heater I-_B
3	SPHSheater_D+A	3	Sorption Pump Heat Switch heater I+_A
4	SPHSheater_D+B	3	Sorption Pump Heat Switch heater I+_B
16	SPHSheater_D-A	3	Sorption Pump Heat Switch heater I-_A
17	SPHSheater_D-B	3	Sorption Pump Heat Switch heater I-_B
5	EVHSheater_D+A	3	Evaporator Heat Switch heater I+_A
6	EVHSheater_D+B	3	Evaporator Heat Switch heater I+_B
18	EVHSheater_D-A	3	Evaporator Heat Switch heater I-_A
19	EVHSheater_D-B	3	Evaporator Heat Switch heater I-_B
7	Spect4heaterD+A	3	HS Spect. 4% heater I+_A
8	Spect4heaterD+B	3	HS Spect. 4% heater I+_B
20	Spect4heaterD-A	3	HS Spect. 4% heater I-_A
21	Spect4heaterD-B	3	HS Spect. 4% heater I-_B
9	Spect2heaterD+A	3	HS Spect. 2% heater I+_A
10	Spect2heaterD+B	3	HS Spect. 2% heater I+_B
22	Spect2heaterD-A	3	HS Spect. 2% heater I-_A
23	Spect2heaterD-B	3	HS Spect. 2% heater I-_B
11	TChheaterD+A	3	300-mK Thermal Control Heater I+_A
12	TChheaterD+B	3	300-mK Thermal Control Heater I+_B
24	TChheaterD-A	3	300-mK Thermal Control Heater I-_A
25	TChheaterD-B	3	300-mK Thermal Control Heater I-_B
13	TChheater_SHD		300-mK Thermal Control Heater shld.

Note: all xx_SHD are onnected to connector body

Unit : FCU
 Sub-unit/Module : SCU/CCHK (Redundant)
 Connector Identifier : J14
 Connector Type : DEMA9S
 Connector Name : HSFCU_J14

Pin#	Signal Name	EMC Class	Signal Description
1			
2	PhStimheaterD+A	3	Photometer Point Stim. heater I+_A
3	PhStimheaterD+B	3	Photometer Point Stim.heater I+_B
4	PhStimheater_SHD		Screen
5			
6			
7	PhStimheaterD+A	3	Photometer Point Stim.heater I-_A
8	PhStimheaterD+B	3	Photometer Point Stim.heater I-_B
9			

Note: all xx_SHD are onnected to connector body

6. Grounding Scheme

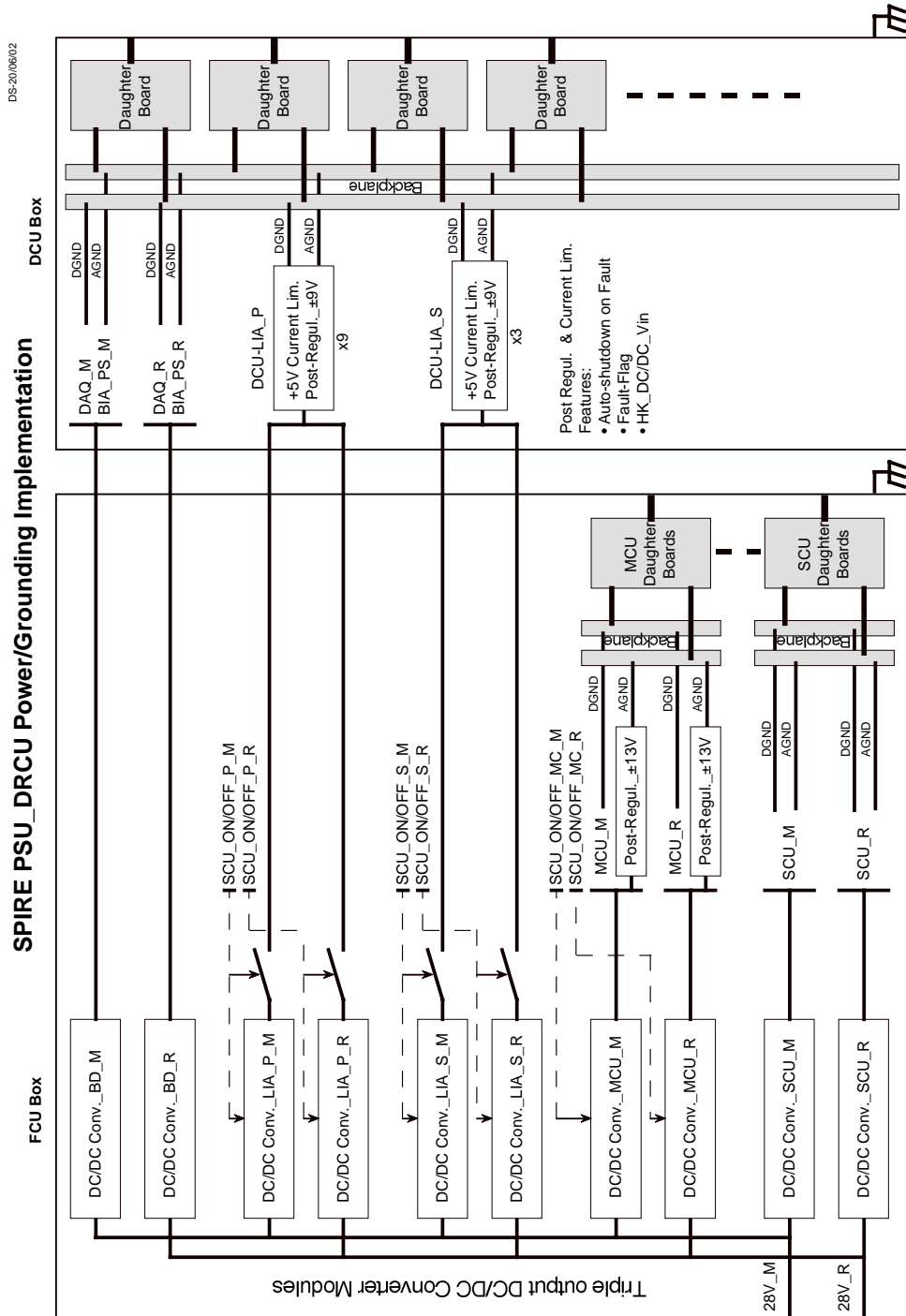

7. Appendix – DRCU Sub-system interconnections

7.1. PSU to DCU interface

This interface concerns exclusively secondary power lines distribution to the DCU electronics. This interface corresponds to the external routing of power lines from the PSU module to the DCU box. No other interface is identified between these to sub-systems.

Unit : DCU (Main)
 Sub-unit/Module : DCU_BP
 Connector Identifier : J03
 Connector Type : DBMA25P
 Connector Name : HSDCU_J03

Pin #	Signal Name	EMC Class	Signal Description
1	LIA_P_P9V_P	1	Positive power supply for LIA_P boards *
2	LIA_P_GND9V_P	1	LIA_P analog voltage common return
3	LIA_P_N9V_P	1	Negative power supply for LIA_P boards *
4	LIA_S_P9V_P	1	Positive power supply for LIA_S boards *
5	LIA_S_GND9V_P	1	LIA_S analog voltage common return
6	LIA_S_N9V_P	1	Negative power supply for LIA_S boards *
7	PDAQ_P9V_P	1	Positive power supply for BIAS & DAQ_IF boards
8	PDAQ_GND9V_P	1	BIAS & DAQ_IF analog voltage common return
9	PDAQ_N9V_P	1	Negative power supply for BIAS & DAQ_IF boards
10	PDAQ_P5V_P	1	Positive power supply for BIAS & DAQ_IF boards
11	LIA_S_P5V_P	1	Positive power supply for LIA_S boards
12	LIA_P_P5V_P	1	Positive power supply for LIA_P boards
13	Chassis		
14	LIA_P_P9V_P	1	Positive power supply for LIA_P boards *
15	LIA_P_GND9V_P	1	LIA_P analog voltage common return
16	LIA_P_N9V_P	1	Negative power supply for LIA_P boards *
17	LIA_S_P9V_P	1	Positive power supply for LIA_S boards *
18	LIA_S_GND9V_P	1	LIA_S analog voltage common return
19	LIA_S_N9V_P	1	Negative power supply for LIA_S boards *
20	PDAQ_P9V_P	1	Positive power supply for BIAS & DAQ_IF boards
21	PDAQ_GND9V_P	1	BIAS & DAQ_IF analog voltage common return
22	PDAQ_N9V_P	1	Negative power supply for BIAS & DAQ_IF boards
23	PDAQ_GND5V_P	1	BIAS & DAQ_IF analog voltage common return
24	LIA_S_GND5V_P	1	LIA_S digital voltage return
25	LIA_P_GND5V_P	1	LIA_P digital voltage return

* Internally regulated to +/- 9V

Unit : DCU (Redundant)
 Sub-unit/Module : DCU_BP
 Connector Identifier : J04
 Connector Type : DBMA25P
 Connector Name : HSDCU_J04

Pin #	Signal Name	EMC Class	Signal Description
1	LIA_P_P9V_R	1	Positive power supply for LIA_P boards *
2	LIA_P_GND9V_R	1	LIA_P analog voltage common return
3	LIA_P_N9V_R	1	Negative power supply for LIA_P boards *
4	LIA_S_P9V_R	1	Positive power supply for LIA_S boards *
5	LIA_S_GND9V_R	1	LIA_S analog voltage common return
6	LIA_S_N9V_R	1	Negative power supply for LIA_S boards *
7	PDAQ_P9V_R	1	Positive power supply for BIAS & DAQ_IF boards
8	PDAQ_GND9V_R	1	BIAS & DAQ_IF analog voltage common return
9	PDAQ_N9V_R	1	Negative power supply for BIAS & DAQ_IF boards
10	PDAQ_P5V_R	1	Positive power supply for BIAS & DAQ_IF boards
11	LIA_S_P5V_R	1	Positive power supply for LIA_S boards
12	LIA_P_P5V_R	1	Positive power supply for LIA_P boards
13	Chassis		
14	LIA_P_P9V_R	1	Positive power supply for LIA_P boards *
15	LIA_P_GND9V_R	1	LIA_P analog voltage common return
16	LIA_P_N9V_R	1	Negative power supply for LIA_P boards *
17	LIA_S_P9V_R	1	Positive power supply for LIA_S boards *
18	LIA_S_GND9V_R	1	LIA_S analog voltage common return
19	LIA_S_N9V_R	1	Negative power supply for LIA_S boards *
20	PDAQ_P9V_R	1	Positive power supply for BIAS & DAQ_IF boards
21	PDAQ_GND9V_R	1	BIAS & DAQ_IF analog voltage common return
22	PDAQ_N9V_R	1	Negative power supply for BIAS & DAQ_IF boards
23	PDAQ_GND5V_R	1	BIAS & DAQ_IF analog voltage common return
24	LIA_S_GND5V_R	1	LIA_S digital voltage return
25	LIA_P_GND5V_R	1	LIA_P digital voltage return

* Internally regulated to +/- 9V

Unit : FCU (Main)
 Sub-unit/Module : PSU
 Connector Identifier : J07
 Connector Type : DBMA25S
 Connector Name : HSFCU_J07

Pin #	Signal Name	EMC Class	Signal Description
1	LIA_P_P9V_P	1	Positive power supply for LIA_P boards *
2	LIA_P_GND9V_P	1	LIA_P analog voltage common return
3	LIA_P_N9V_P	1	Negative power supply for LIA_P boards *
4	LIA_S_P9V_P	1	Positive power supply for LIA_S boards *
5	LIA_S_GND9V_P	1	LIA_S analog voltage common return
6	LIA_S_N9V_P	1	Negative power supply for LIA_S boards *
7	PDAQ_P9V_P	1	Positive power supply for BIAS & DAQ_IF boards
8	PDAQ_GND9V_P	1	BIAS & DAQ_IF analog voltage common return
9	PDAQ_N9V_P	1	Negative power supply for BIAS & DAQ_IF boards
10	PDAQ_P5V_P	1	Positive power supply for BIAS & DAQ_IF boards
11	LIA_S_P5V_P	1	Positive power supply for LIA_S boards
12	LIA_P_P5V_P	1	Positive power supply for LIA_P boards
13	Chassis		
14	LIA_P_P9V_P	1	Positive power supply for LIA_P boards *
15	LIA_P_GND9V_P	1	LIA_P analog voltage common return
16	LIA_P_N9V_P	1	Negative power supply for LIA_P boards *
17	LIA_S_P9V_P	1	Positive power supply for LIA_S boards *
18	LIA_S_GND9V_P	1	LIA_S analog voltage common return
19	LIA_S_N9V_P	1	Negative power supply for LIA_S boards *
20	PDAQ_P9V_P	1	Positive power supply for BIAS & DAQ_IF boards
21	PDAQ_GND9V_P	1	BIAS & DAQ_IF analog voltage common return
22	PDAQ_N9V_P	1	Negative power supply for BIAS & DAQ_IF boards
23	PDAQ_GND5V_P	1	BIAS & DAQ_IF analog voltage common return
24	LIA_S_GND5V_P	1	LIA_S digital voltage return
25	LIA_P_GND5V_P	1	LIA_P digital voltage return

* Internally regulated to +/- 9V

Unit : FCU (Redundant)
 Sub-unit/Module : PSU
 Connector Identifier : J08
 Connector Type : DBMA25S
 Connector Name : HSFCU_J08

Pin #	Signal Name	EMC Class	Signal Description
1	LIA_P_P9V_R	1	Positive power supply for LIA_P boards *
2	LIA_P_GND9V_R	1	LIA_P analog voltage common return
3	LIA_P_N9V_R	1	Negative power supply for LIA_P boards *
4	LIA_S_P9V_R	1	Positive power supply for LIA_S boards *
5	LIA_S_GND9V_R	1	LIA_S analog voltage common return
6	LIA_S_N9V_R	1	Negative power supply for LIA_S boards *
7	PDAQ_P9V_R	1	Positive power supply for BIAS & DAQ_IF boards
8	PDAQ_GND9V_R	1	BIAS & DAQ_IF analog voltage common return
9	PDAQ_N9V_R	1	Negative power supply for BIAS & DAQ_IF boards
10	PDAQ_P5V_R	1	Positive power supply for BIAS & DAQ_IF boards
11	LIA_S_P5V_R	1	Positive power supply for LIA_S boards
12	LIA_P_P5V_R	1	Positive power supply for LIA_P boards
13	Chassis	1	
14	LIA_P_P9V_R	1	Positive power supply for LIA_P boards *
15	LIA_P_GND9V_R	1	LIA_P analog voltage common return
16	LIA_P_N9V_R	1	Negative power supply for LIA_P boards *
17	LIA_S_P9V_R	1	Positive power supply for LIA_S boards *
18	LIA_S_GND9V_R	1	LIA_S analog voltage common return
19	LIA_S_N9V_R	1	Negative power supply for LIA_S boards *
20	PDAQ_P9V_R	1	Positive power supply for BIAS & DAQ_IF boards
21	PDAQ_GND9V_R	1	BIAS & DAQ_IF analog voltage common return
22	PDAQ_N9V_R	1	Negative power supply for BIAS & DAQ_IF boards
23	PDAQ_GND5V_R	1	BIAS & DAQ_IF analog voltage common return
24	LIA_S_GND5V_R	1	LIA_S digital voltage return
25	LIA_P_GND5V_R	1	LIA_P digital voltage return

* Internally regulated to +/- 9V

7.2. PSU to MCU interface

This interface concerns exclusively secondary power lines distribution to the MCU electronics. This interface corresponds to the internal routing of power lines from the distribution board to the MCU back plane. No other interface is identified between these to sub-systems.

Unit : MCU (Main)
 Sub-unit/Module : MCU_BP
 Connector Identifier : J31
 Connector Type : DBMA25P
 Connector Name : HSFCU_J31

Pin #	Signal Name	EMC Class	Signal Description
1	P5Vdig_P	1	Positive (+5V) digital supply
2	P5Vdig_P	1	Positive (+5V) digital supply
3	P5Vdig_P	1	Positive (+5V) digital supply
4	P5Vdig_P	1	Positive (+5V) digital supply
5			
6			
7			
8	-		
9	P15Vmot_P	1	Positive (+15V) analog supply
10	P15Vmot_P	1	Positive (+15V) analog supply
11	N15Vmot_P	1	Negative (- 15 V) analog supply
12	N15Vmot_P	1	Negative (- 15 V) analog supply
13			
14	0Vdig_P	1	Return for positive (+5V) digital supply
15	0Vdig_P	1	Return for positive (+5V) digital supply
16	0Vdig_P	1	Return for positive (+5V) digital supply
17	0Vdig_P	1	Return for positive (+5V) digital supply
18			
19			
20			
21			
22	0Vmot_P	1	Return for analog (+/-15 V) supply
23	0Vmot_P	1	Return for analog (+/-15 V) supply
24	0Vmot_P	1	Return for analog (+/-15 V) supply
25	0Vmot_P	1	Return for analog (+/-15 V) supply

Unit : MCU (redundant)
 Sub-unit/Module : MCU_BP
 Connector Identifier : J32
 Connector Type : DBMA25P
 Connector Name : HSFCU_J32

Pin #	Signal Name	EMC Class	Signal Description
1	P5Vdig_R	1	Positive (+5V) digital supply
2	P5Vdig_R	1	Positive (+5V) digital supply
3	P5Vdig_R	1	Positive (+5V) digital supply
4	P5Vdig_R	1	Positive (+5V) digital supply
5			
6			
7			
8	-		
9	P15Vmot_R	1	Positive (+15V) analog supply
10	P15Vmot_R	1	Positive (+15V) analog supply
11	N15Vmot_R	1	Negative (- 15 V) analog supply
12	N15Vmot_R	1	Negative (- 15 V) analog supply
13			
14	0Vdig_R	1	Return for positive (+5V) digital supply
15	0Vdig_R	1	Return for positive (+5V) digital supply
16	0Vdig_R	1	Return for positive (+5V) digital supply
17	0Vdig_R	1	Return for positive (+5V) digital supply
18			
19			
20			
21			
22	0Vmot_R	1	Return for analog (+/-15 V) supply
23	0Vmot_R	1	Return for analog (+/-15 V) supply
24	0Vmot_R	1	Return for analog (+/-15 V) supply
25	0Vmot_R	1	Return for analog (+/-15 V) supply

Unit : FCU (Main)
 Sub-unit/Module : PSU
 Connector Identifier : J09
 Connector Type : DBMA25S
 Connector Name : HSFCU_J09

Pin #	Signal Name	EMC Class	Signal Description
1	P5Vdig_P	1	Positive (+5V) digital supply
2	P5Vdig_P	1	Positive (+5V) digital supply
3	P5Vdig_P	1	Positive (+5V) digital supply
4	P5Vdig_P	1	Positive (+5V) digital supply
5			
6			
7			
8	-		
9	P15Vmot_P	1	Positive (+15V) analog supply
10	P15Vmot_P	1	Positive (+15V) analog supply
11	N15Vmot_P	1	Negative (- 15 V) analog supply
12	N15Vmot_P	1	Negative (- 15 V) analog supply
13			
14	0Vdig_P	1	Return for positive (+5V) digital supply
15	0Vdig_P	1	Return for positive (+5V) digital supply
16	0Vdig_P	1	Return for positive (+5V) digital supply
17	0Vdig_P	1	Return for positive (+5V) digital supply
18			
19			
20			
21			
22	0Vmot_P	1	Return for analog (+/-15 V) supply
23	0Vmot_P	1	Return for analog (+/-15 V) supply
24	0Vmot_P	1	Return for analog (+/-15 V) supply
25	0Vmot_P	1	Return for analog (+/-15 V) supply

Unit : FCU (redundant)
 Sub-unit/Module : PSU
 Connector Identifier : J10
 Connector Type : DBMA25S
 Connector Name : HSFCU_J10

Pin #	Signal Name	EMC Class	Signal Description
1	P5Vdig_R	1	Positive (+5V) digital supply
2	P5Vdig_R	1	Positive (+5V) digital supply
3	P5Vdig_R	1	Positive (+5V) digital supply
4	P5Vdig_R	1	Positive (+5V) digital supply
5			
6			
7			
8	-		
9	P15Vmot_R	1	Positive (+15V) analog supply
10	P15Vmot_R	1	Positive (+15V) analog supply
11	N15Vmot_R	1	Negative (- 15 V) analog supply
12	N15Vmot_R	1	Negative (- 15 V) analog supply
13			
14	0Vdig_R	1	Return for positive (+5V) digital supply
15	0Vdig_R	1	Return for positive (+5V) digital supply
16	0Vdig_R	1	Return for positive (+5V) digital supply
17	0Vdig_R	1	Return for positive (+5V) digital supply
18			
19			
20			
21			
22	0Vmot_R	1	Return for analog (+/-15 V) supply
23	0Vmot_R	1	Return for analog (+/-15 V) supply
24	0Vmot_R	1	Return for analog (+/-15 V) supply
25	0Vmot_R	1	Return for analog (+/-15 V) supply

7.3. PSU to SCU interface

This interface concerns exclusively secondary power lines distribution to the FCU electronics for distribution to all the relevant S/S. No other interface is identified between these to sub-systems.

Unit : SCU (main)
Sub-unit/Module : SCU_BP
Connector Identifier : J35
Connector Type : DAMA15P
Connector Name : HSFCU_J35

Pin #	Signal Name	EMC Class	Signal Description
1	SCU_P5_P	1	Positive (+5V) digital supply
2	SCU_P9_P	1	Positive (+9V) analog supply
3	SCU_N9_P	1	Negative (- 9V) analog supply
	OnOff_Cmd_Shield		
5	MCU_OnOff_Cmd_P	2	Bi-level on/off command for MCU S/S
	PSU_ThSens_Shield		
7	PSU_ThSens1+_P	3	PSU thermal sensor 1 voltage bias
8	PSU_ThSens2+_P	3	PSU thermal sensor 2 voltage bias
9	SCU_P5_RTN_P	1	Return for positive (+5V) digital supply
10	SCU_9_RTN_P	1	Return for analog (+/-9 V) supply
11			
12	LIAP_OnOff_Cmd_P	2	Bi-level on/off command for DCU/LIA_P S/S
13	LIAS_OnOff_Cmd_P	2	Bi-level on/off command for DCU/LIA_S S/S
14	PSU_ThSens1-_P	3	PSU thermal sensor 1 current sense
15	PSU_ThSens2-_P	3	PSU thermal sensor 2 current sense

Unit : SCU (redundant)
Sub-unit/Module : SCU_BP
Connector Identifier : J36
Connector Type : DAMA15P
Connector Name : HSFCU_J36

Pin #	Signal Name	EMC Class	Signal Description
1	SCU_P5_R	1	Positive (+5V) digital supply
2	SCU_P9_R	1	Positive (+9V) analog supply
3	SCU_N9_R	1	Negative (- 9V) analog supply
	OnOff_Cmd_Shield		
5	MCU_OnOff_Cmd_R	2	Bi-level on/off command for MCU S/S
	PSU_ThSens_Shield		
7	PSU_ThSens1+_R	3	PSU thermal sensor 1 voltage bias
8	PSU_ThSens2+_R	3	PSU thermal sensor 2 voltage bias

9	SCU_P5_RTN_R	1	Return for positive (+5V) digital supply
10	SCU_9_RTN_R	1	Return for analog (+/-9 V) supply
11			
12	LIAP_OnOff_Cmd_R	2	Bi-level on/off command for DCU/LIA_P S/S
13	LIAS_OnOff_Cmd_R	2	Bi-level on/off command for DCU/LIA_S S/S
14	PSU_ThSens1-_R	3	PSU thermal sensor 1 current sense
15	PSU_ThSens2-_R	3	PSU thermal sensor 2 current sense

Unit : FCU (main)
 Sub-unit/Module : PSU
 Connector Identifier : J33
 Connector Type : DAMA15S
 Connector Name : HSFCU_J33

Pin #	Signal Name	EMC Class	Signal Description
1	SCU_P5_P	1	Positive (+5V) digital supply
2	SCU_P9_P	1	Positive (+9V) analog supply
3	SCU_N9_P	1	Negative (- 9V) analog supply
	OnOff_Cmd_Shield		
5	MCU_OnOff_Cmd_P	2	Bi-level on/off command for MCU S/S
	PSU_ThSens_Shield		
7	PSU_ThSens1+_P	3	PSU thermal sensor 1 voltage bias
8	PSU_ThSens2+_P	3	PSU thermal sensor 2 voltage bias
9	SCU_P5_RTN_P	1	Return for positive (+5V) digital supply
10	SCU_9_RTN_P	1	Return for analog (+/-9 V) supply
11			
12	LIAP_OnOff_Cmd_P	2	Bi-level on/off command for DCU/LIA_P S/S
13	LIAS_OnOff_Cmd_P	2	Bi-level on/off command for DCU/LIA_S S/S
14	PSU_ThSens1-_P	3	PSU thermal sensor 1 current sense
15	PSU_ThSens2-_P	3	PSU thermal sensor 2 current sense

Unit : FCU (redundant)
 Sub-unit/Module : PSU
 Connector Identifier : J34
 Connector Type : DAMA15S
 Connector Name : HSFCU_J34

Pin #	Signal Name	EMC Class	Signal Description
1	SCU_P5_R	1	Positive (+5V) digital supply
2	SCU_P9_R	1	Positive (+9V) analog supply
3	SCU_N9_R	1	Negative (- 9V) analog supply
	OnOff_Cmd_Shield		
5	MCU_OnOff_Cmd_R	2	Bi-level on/off command for MCU S/S
	PSU_ThSens_Shield		
7	PSU_ThSens1+_R	3	PSU thermal sensor 1 voltage bias
8	PSU_ThSens2+_R	3	PSU thermal sensor 2 voltage bias

9	SCU_P5_RTN_R	1	Return for positive (+5V) digital supply
10	SCU_9_RTN_R	1	Return for analog (+/-9 V) supply
11			
12	LIAP_OnOff_Cmd_R	2	Bi-level on/off command for DCU/LIA_P S/S
13	LIAS_OnOff_Cmd_R	2	Bi-level on/off command for DCU/LIA_S S/S
14	PSU_ThSens1- R	3	PSU thermal sensor 1 current sense
15	PSU_ThSens2- R	3	PSU thermal sensor 2 current sense